



POLITECHNIKA  
LUBELSKA  
LUBLIN UNIVERSITY  
OF TECHNOLOGY

## Machine Parts II

### *Rolling bearings* \_\_\_\_\_

*Introduction and fundamental information on rolling bearing selection  
and arrangement design*



Lublin 2026

Łukasz Jedliński

# Presentation plan

## **1. Introduction – general information**

- 1.1. Classification
- 1.2. Properties of rolling bearings
- 1.3. Bearing designation

## **2. Bearing selection**

- 2.1. General information
- 2.2. Two support arrangements
- 2.3. Selection criteria
- 2.4. Bearing failures modes

## **3. Selected issues in bearing arrangement design**

- 3.1. Selection of bearing fits
- 3.2. Sealing of bearing

# Introduction – general information

**Bearings** are components that reduce friction during the relative motion of parts, enabling the transfer of forces and moments while allowing precise motion only in the required direction.

The first and simplest form of bearing was the journal (plain or sliding) bearing. The surfaces of the connected parts were shaped to move smoothly relative to one another, without the need for additional components. Over time, journal bearings evolved into various types, and their designs can be highly sophisticated. Rolling bearings, in the form known today and capable of competing with journal bearings, were produced in the twentieth century. Their development was initially limited by the availability of high-quality materials and the machining precision required to ensure reliable and long-term operation.

As mentioned previously, bearings can be classified according to their operating principle into journal bearings and rolling bearings.

Journal (plain or sliding) bearings operate on the principle of one element sliding over another with or without an intermediate medium. In rolling bearings, the elements roll during motion. The basic idea behind rolling bearings is that rolling friction is lower than sliding friction.

In general bearings enable components to perform rotational motion and translational motion (linear bearings).

There are other types of commercially produced bearings such as air and magnetic bearings which can be classified as journal bearings.

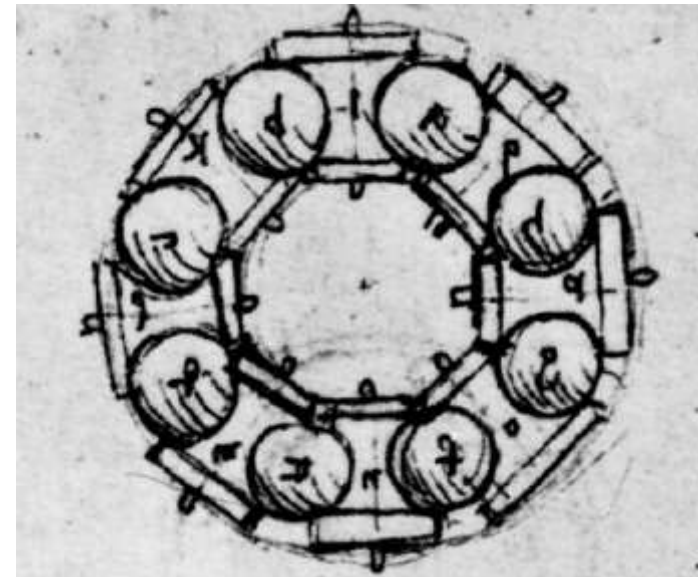

Fig. Thrust ball bearing design (ca. 1500) in Codex Madrid by Leonardo da Vinci [Harris 2007]

# Introduction – general information

**Rolling bearing advantages** are determined by the following characteristics:

- Low friction at operating speeds, resulting in lower temperatures, higher efficiency, and suitability for low-speed applications.
- Availability in a wide range of standardised types and sizes, with unified dimensions, allowing use in most applications.
- Relatively low cost, especially for small bearings.
- Well-established bearing selection methods and high reliability.
- High motion accuracy.
- Ability to operate without or with minimal maintenance.
- Small axial space requirement.
- Capability of being preloaded, which increases stiffness and eliminates internal clearance.



Fig. Crankshaft with bearing shells

[[https://allegro.pl/oferta/wal-korbowy-panewki-podstawa-cx-5-3-2-0b-skajactiv-8928169890?utm\\_feed=aa34192d-eee2-4419-9a9a-d66b9dfe24&utm\\_source=google&utm\\_medium=pc&utm\\_campaign=mrzcz\\_vehicle-parts\\_motoacc\\_pla&ev\\_adgr=general&ev\\_campaign\\_id=222008451698&utm\\_keyword=&gad\\_source=1&gad\\_campaignid=222008451698&gclid=OAAAAAD24kbPhu8r2\\_hb1GmX55GqWwwe4w&gclid=EAtalQobChMIISW5\\_KD3kQMVDfURBR1o8w88EAQYByABEgExPD\\_BwE\]](https://allegro.pl/oferta/wal-korbowy-panewki-podstawa-cx-5-3-2-0b-skajactiv-8928169890?utm_feed=aa34192d-eee2-4419-9a9a-d66b9dfe24&utm_source=google&utm_medium=pc&utm_campaign=mrzcz_vehicle-parts_motoacc_pla&ev_adgr=general&ev_campaign_id=222008451698&utm_keyword=&gad_source=1&gad_campaignid=222008451698&gclid=OAAAAAD24kbPhu8r2_hb1GmX55GqWwwe4w&gclid=EAtalQobChMIISW5_KD3kQMVDfURBR1o8w88EAQYByABEgExPD_BwE])]

**Rolling bearing disadvantages** are determined by the following limitations:

- Limited maximum rotational speed.
- Low resistance to impulsive (shock) loads.
- Higher cost compared with journal bearings, particularly for medium and large sizes.
- Rolling bearings generate vibration and noise, whereas journal bearings with an intermediate medium damp vibrations.
- Requirement for radial space.
- Limited operating life, whereas journal bearings with hydrodynamic lubrication can operate for an almost unlimited duration.

# Introduction – general information

**The nomenclature** and structure of rolling bearings are illustrated using a ball bearing as an example. A typical rolling bearing consists of four main elements: rolling elements, an inner ring, an outer ring and a cage (separator or retainer).

Additional components may be present such as steel shields or rubber seals, an aligning seat washer, a snap ring or a thrust collar depending on the type of rolling bearing.

In general, lubrication is required for the proper operation of rolling bearings. Only ceramic bearings have minimal lubrication requirements, and some polymer bearings can operate without lubrication.

The simplest rolling bearings may consist of only two elements such as rolling elements and a ring or rolling elements and a cage. This configuration typically occurs in needle roller bearings.

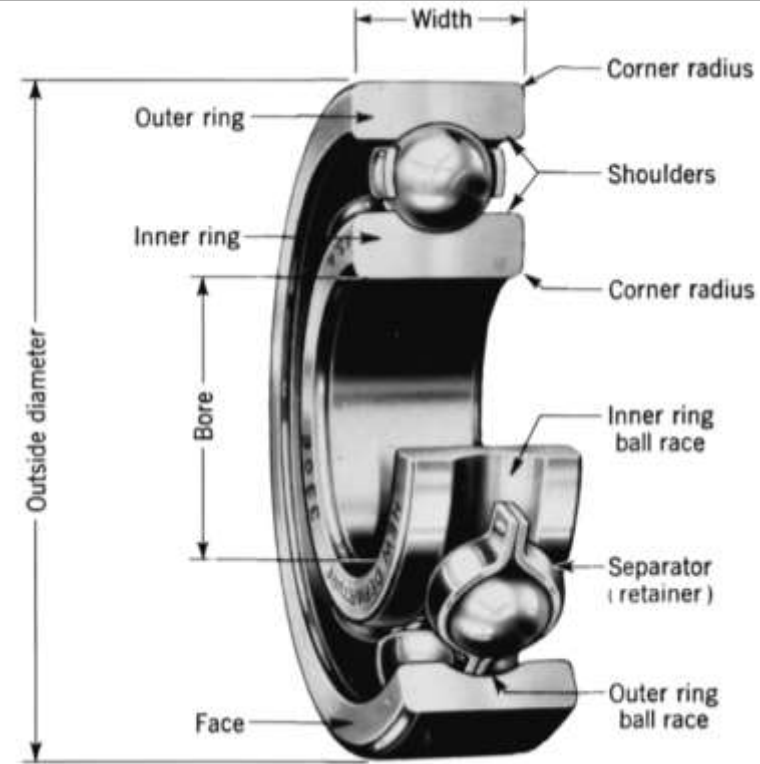
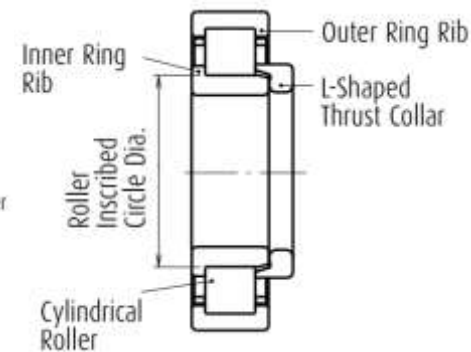
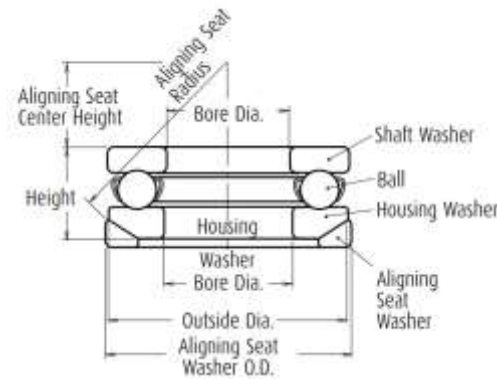
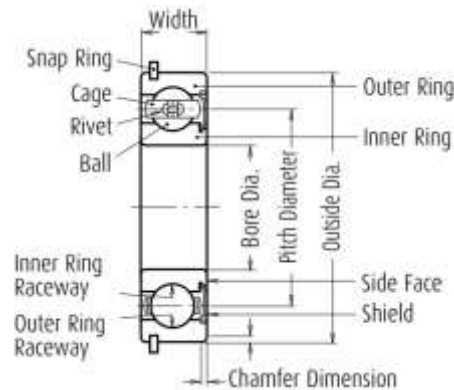

Fig. Nomenclature of ball bearing [Budynas 2008]



Figs. [NSK 2011]

# Introduction – general information

## 1. Classification

Rolling bearings are most often classified according to two criteria: the direction of the applied load and the shape of the rolling elements.

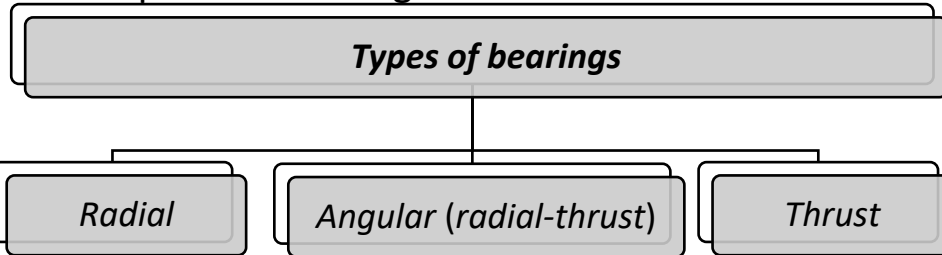

**Radial bearings** primarily carry radial loads and may have a limited capacity to support small axial (thrust) loads – contact angles of up to  $15^\circ$ .

**Angular (radial-thrust) bearings** carry both radial and axial (thrust) loads – contact angle  $15^\circ \div 75^\circ$ .

**Thrust bearings** primarily carry axial (thrust) loads and may have a limited capacity to support small radial loads – contact angles  $75^\circ \div 90^\circ$ . Currently standard thrust bearings carry only axial (thrust) loads.

**Types of bearings\*** — bearings are also classified as **radial** (contact angle  $0^\circ \div 45^\circ$ ) or **thrust** bearings (contact angle  $45^\circ \div 90^\circ$ ) as adopted in SKF or NSK nomenclature.

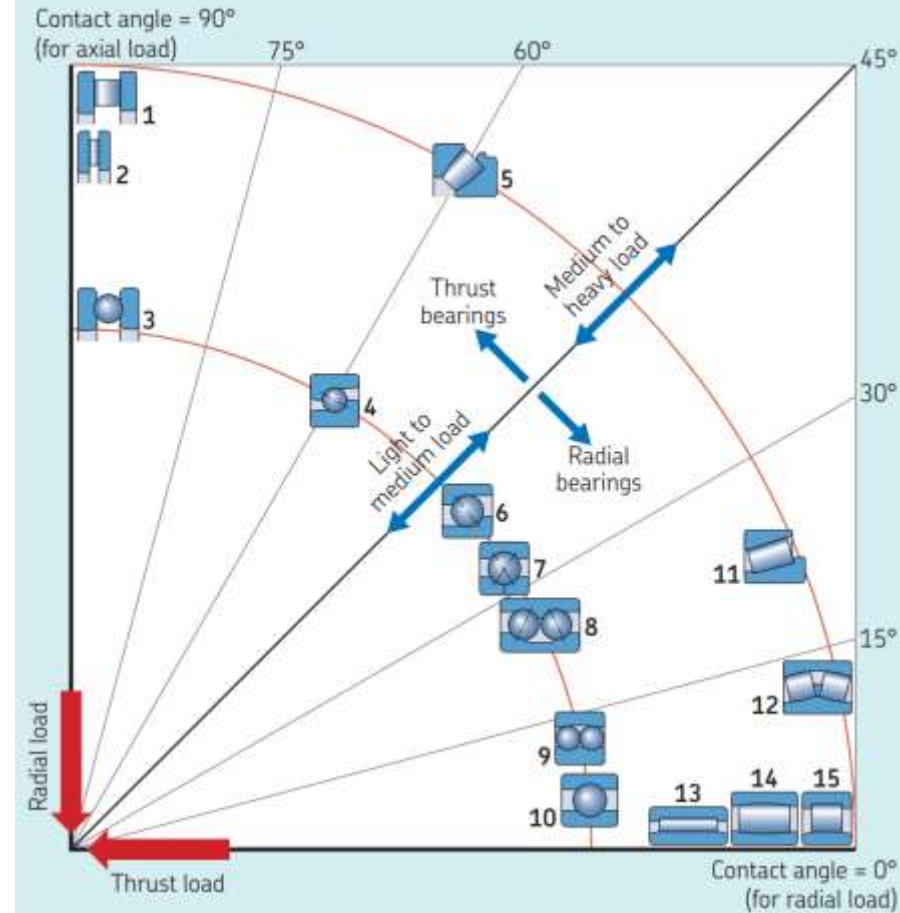

Fig. Application of bearings based on load type [SKF 2018]

# Introduction – general information

## 1. Classification

Most parts are supported by two bearings. When a single bearing is used to support a component, moment loads also need to be considered. The application of a single rolling bearing is generally limited to two or more row bearings. Multi-row bearings function like two or more separate bearings, but the bearing is more compact in size and easier to use.

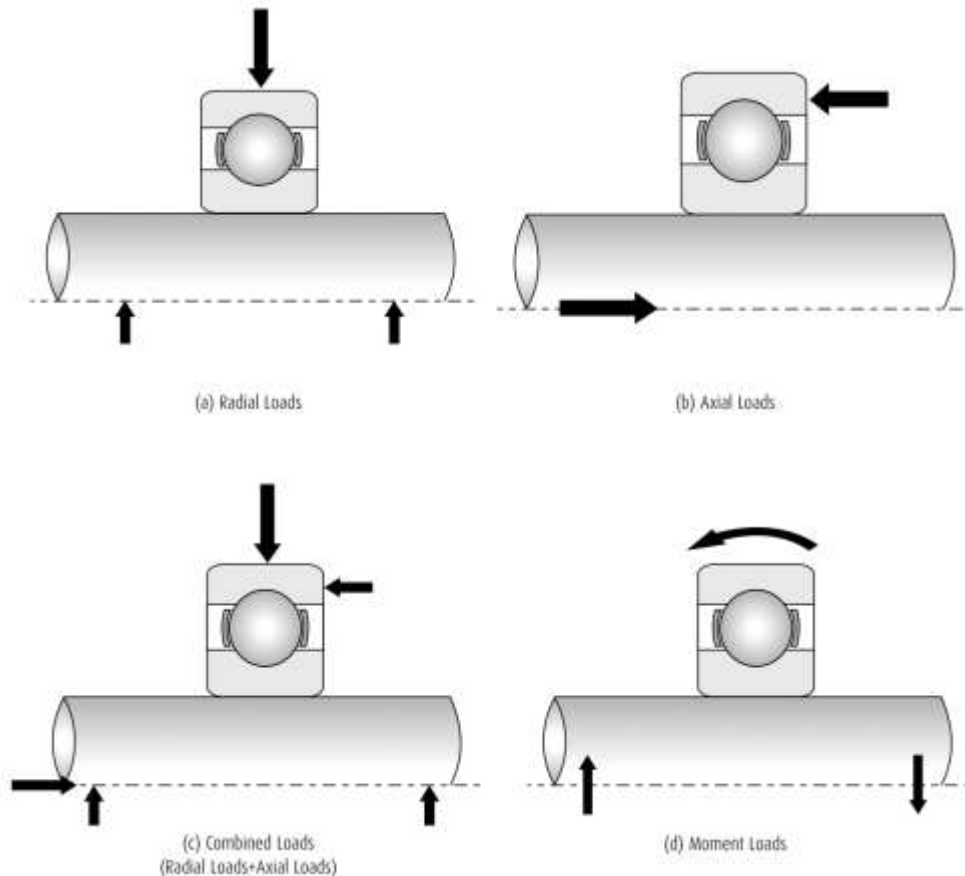
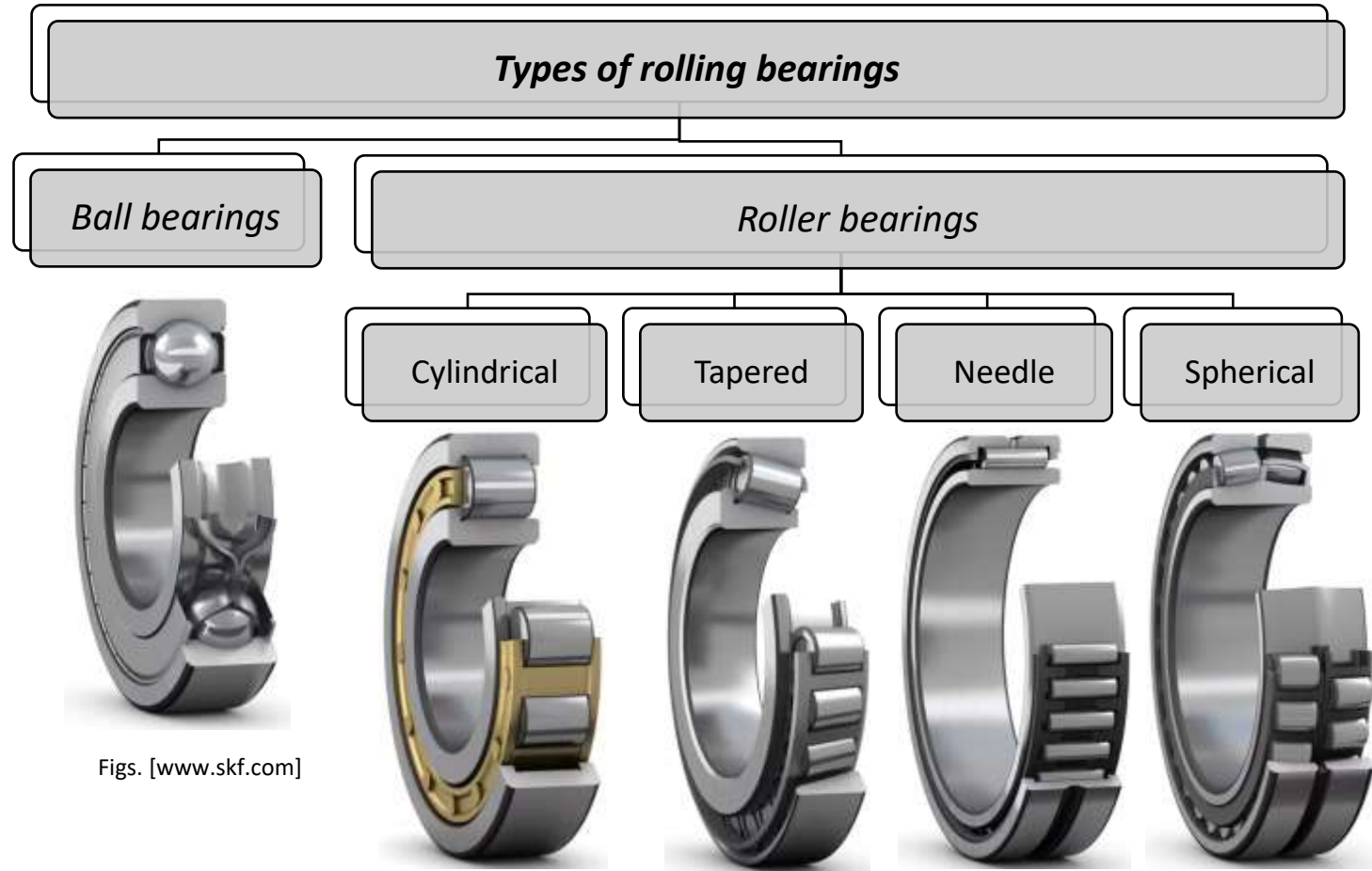

Fig. Double row angular contact ball bearing [www.skf.com]

Fig. Types of bearing loads [NSK 2011]

# Introduction – general information

## 1. Classification



	Ball bearing	Roller bearing
Contact with raceway	<p>Point contact Contact surface is oval when a load is applied.</p>	<p>Linear contact Contact surface is generally rectangular when a load is applied.</p>

Fig. [NTN 2024]

**The most used type of rolling bearing is the ball bearing.** It is suitable for standard applications due to the following features: good load capacity, the ability to carry both radial and axial loads in most bearing designs, low friction, quiet operation, high-speed capability, price, precision and the option to be sealed with grease allowing maintenance-free operation.

The main reason for using roller bearings is their higher load capacity and the associated increased rigidity and resistance to shock loads compared with ball bearings of similar dimensions. If space is limited, roller bearings are the better choice.

# Introduction – general information

## 2. Properties of rolling bearings

Table [NSK 2011]

Features		Bearing Types																				
		Deep Groove Ball Bearings	Magnets Bearings	Angular Contact Ball Bearings	Double-Row Angular Contact Ball Bearings	Duplex Angular Contact Ball Bearings	Four-Point Contact Ball Bearings	Self-Aligning Ball Bearings	Cylindrical Roller Bearings	Double-Row Cylindrical Roller Bearings	Cylindrical Roller Bearings with Single Rib	Cylindrical Roller Bearings with Thrust Collars	Needle Roller Bearings	Tapered Roller Bearings	Double- and Multiple-Row Tapered Roller Bearings	Spherical Roller Bearings	Thrust Ball Bearings	Thrust Ball Bearings with Aligning Seat	Double-Direction Angular Contact Thrust Ball Bearings	Thrust Cylindrical Roller Bearings	Thrust Tapered Roller Bearings	Thrust Spherical Roller Bearings
Load Capacity	Radial Loads	○	○	○	○	○	○	○	○	○	○	○	○	○	○	○	○	○	○	○	○	○
	Axial Loads	○	○	○	○	○	○	×	×	○	○	×	○	○	○	○	○	○	○	○	○	○
	Combined Loads	○	○	○	○	○	○	×	×	○	○	×	○	○	○	○	○	○	○	○	○	○
	High Speeds	○	○	○	○	○	○	○	○	○	○	○	○	○	○	○	○	○	○	○	○	○
	High Accuracy	○		○		○		○	○				○				○		○			
	Low Noise and Torque	○						○														
	Rigidity					○		○	○	○	○	○	○	○	○				○	○	○	
	Angular Misalignment	○	○	○	○	○	○	○	○	○	○	○	○	○	○	○	○	○	○	○	○	○
	Self-Aligning Capability						☆								☆		☆					☆
	Ring Separability		☆					☆	☆	☆	☆	☆	☆	☆	☆		☆	☆	☆	☆	☆	☆
	Fixed-End Bearing	☆			☆	☆	☆	☆			☆				☆	☆						
	Free-End Bearing	★			★	★	★	★	☆	☆		☆			★	★						

Excellent   
 Good   
 Fair   
 Poor   
 Impossible   
 One direction only   
 Two directions

☆ Applicable   
 ★ Applicable, but it is necessary to allow shaft contraction/elongation at fitting surfaces of bearings.

# Introduction – general information

## 3. Bearing designation

### Designations for SKF rolling bearings

Examples

R	NU 2212	ECML
W	6008	C3
	23022	2CS

Prefix

Space or non-separated

Basic designation

Space, oblique stroke or hyphen

Suffix

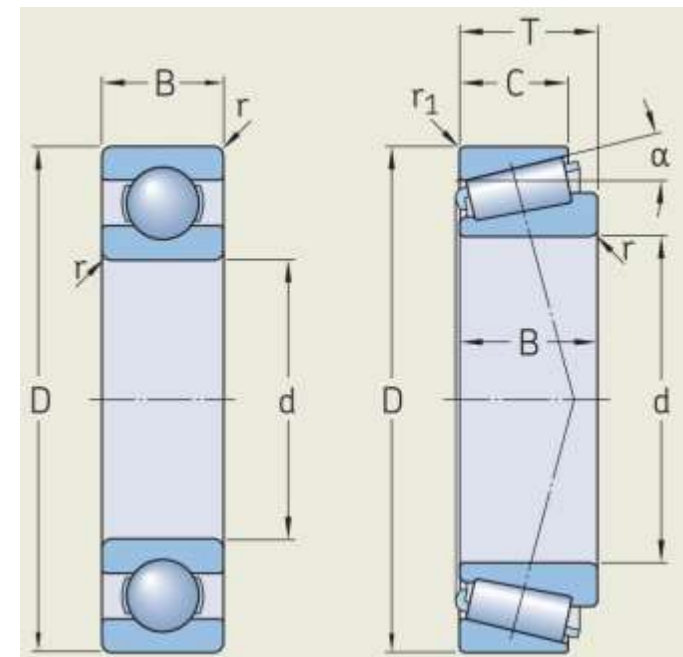
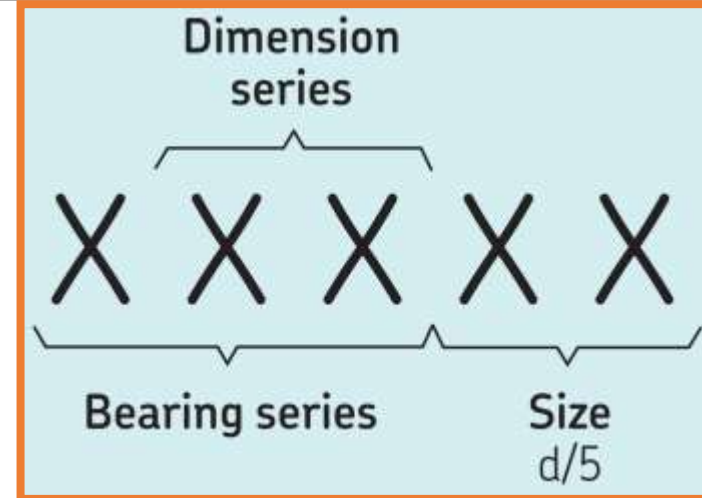

Figs. [SKF 2018]

Fig. Boundary dimensions [SKF 2018]



# Introduction – general information

## 3. Bearing designation

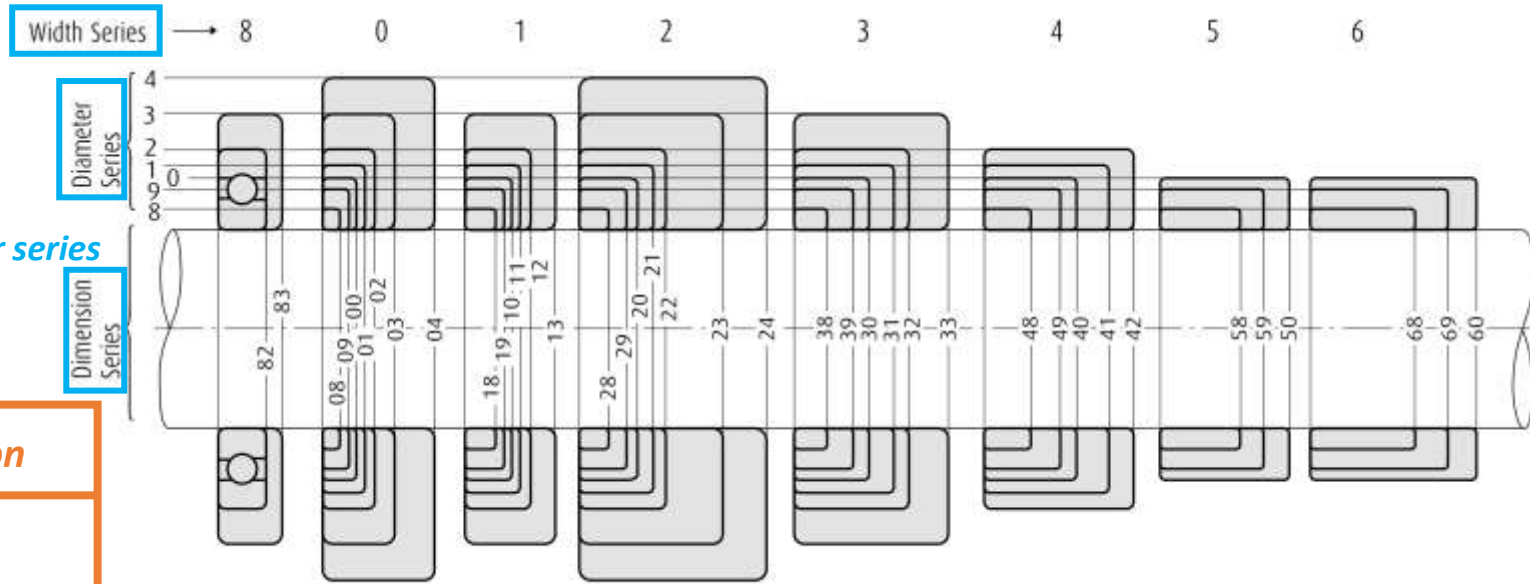
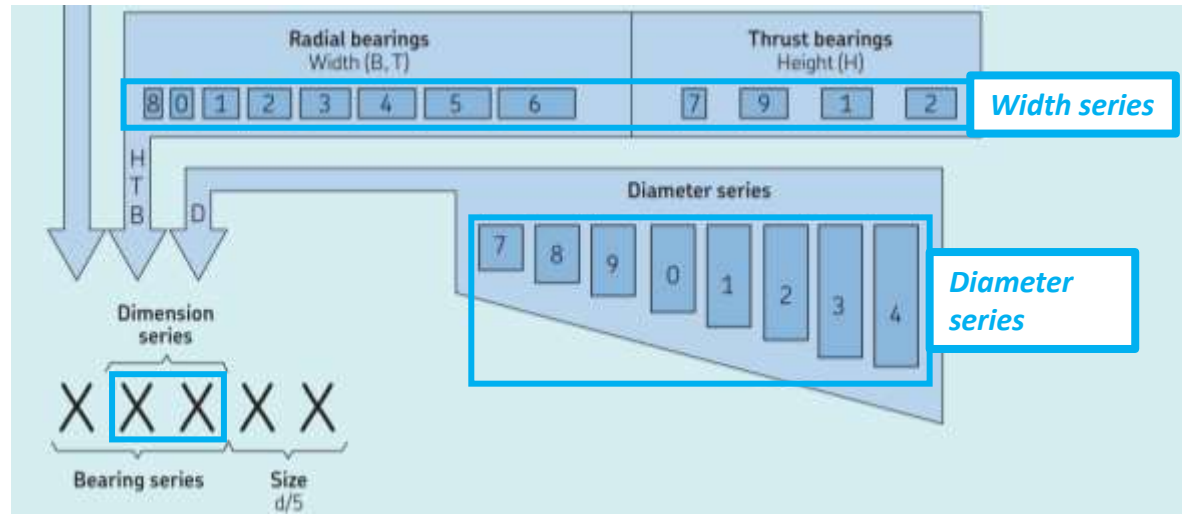
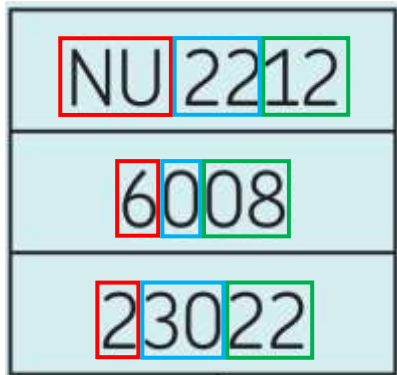

Fig. 6.6 Comparison of Cross Sections of Radial Bearings (except Tapered Roller Bearings) for various Dimensional Series [NSK 2011]

### Basic designation

Bearing type  
Dimension series  
Bore diameter code



Figs. [SKF 2018]



# Introduction – general information

## 3. Bearing designation

### Basic designation

Bearing type

Dimension series

Bore diameter code

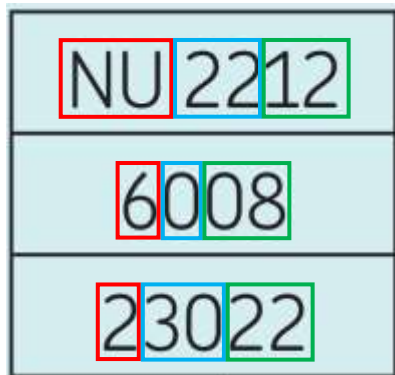

### Bore diameter $d < 10$ mm

Usually uncoded

e.g. 629

$d = 9$  mm.

### Bore diameter $10 \text{ mm} \leq d < 20$ mm

00 -  $d = 10$  mm,

01 -  $d = 12$  mm,

02 -  $d = 15$  mm,

03 -  $d = 17$  mm.

### Bore diameter $20 \text{ mm} \leq d \leq 450$ mm

$d = XX \times 5$  [mm],

e.g.

$d = 12 \times 5 = 60$  mm,

$d = 08 \times 5 = 40$  mm.

### Bore diameter $450 \text{ mm} < d$

Custom manufacturer designation

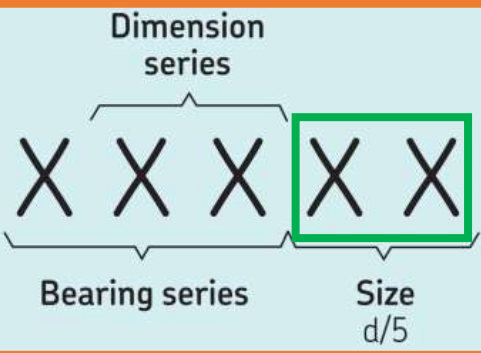
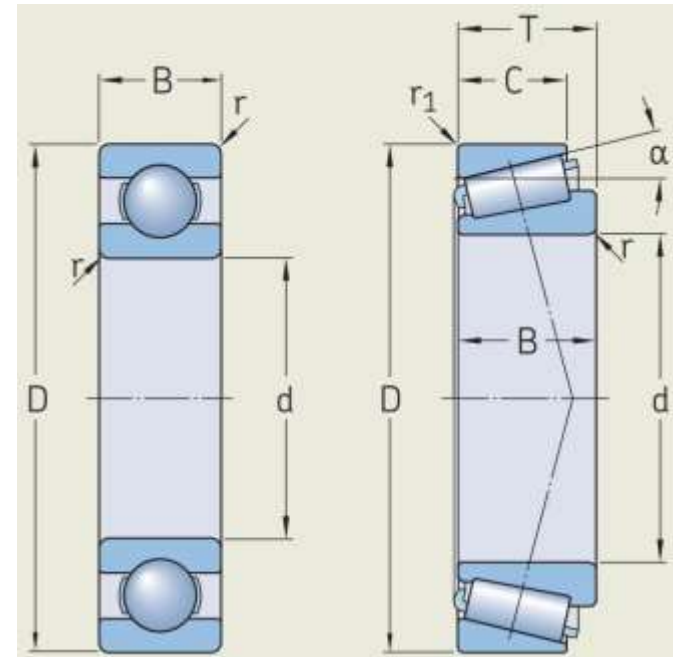

# Introduction – general information

## 3. Bearing designation

### Suffix

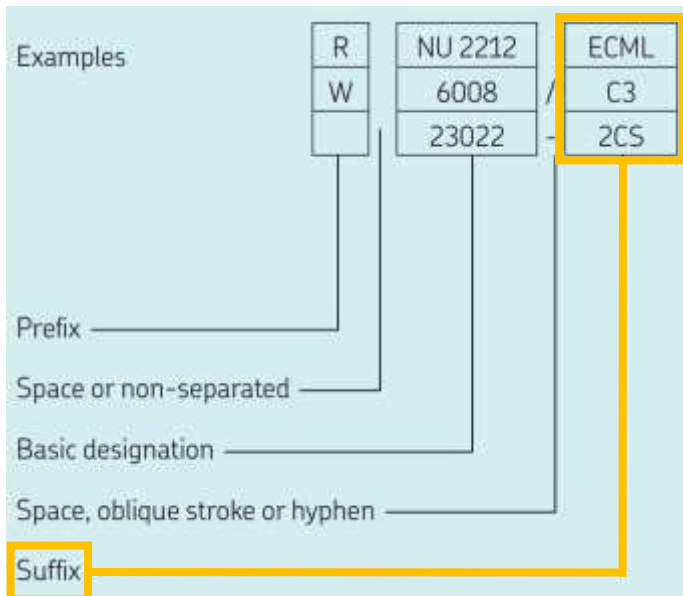

Fig. [SKF 2018]

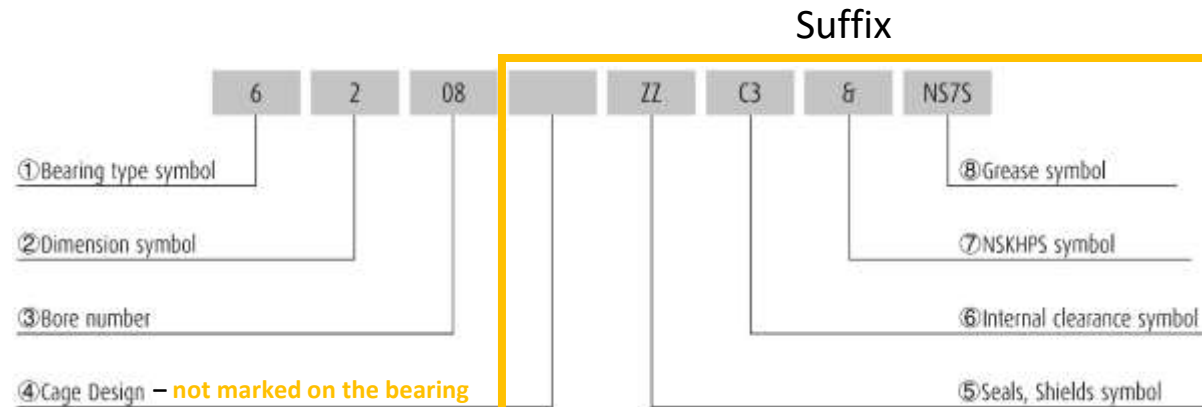

Fig. [NSK 2011]

# Introduction – general information

## 3. Bearing designation

### Suffix – seals and shields

The type and properties of shields and seals may vary depending on the bearing manufacturer.

Type	Shielded Type (ZZ Type)	Non-Contact Rubber Sealed Type (VV Type)	Contact Rubber Sealed Type (DDU Type)
Torque	Low	Low	Higher than ZZ, VV types due to contact seal
Speed capability	Good	Good	Limited by contact seals
Grease sealing effectiveness	Good	Better than ZZ type	A little better than VV type
Dust resistance	Good	Better than ZZ type (usable in moderately dusty environment)	Best (usable even in very dusty environment)
Water resistance	Not suitable	Not suitable	Good (usable even if fluid is splashed on bearing)
Operating temperature (°)	-10 to +110°C	-10 to +110°C	-10 to +100°C

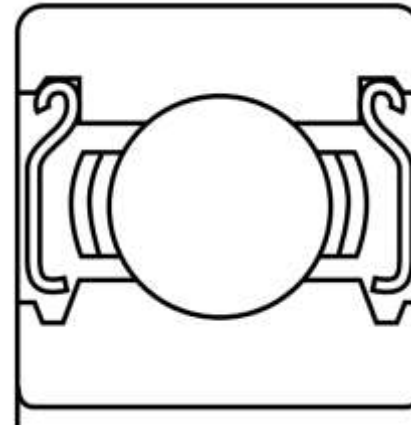

Shielded Type (ZZ Type)

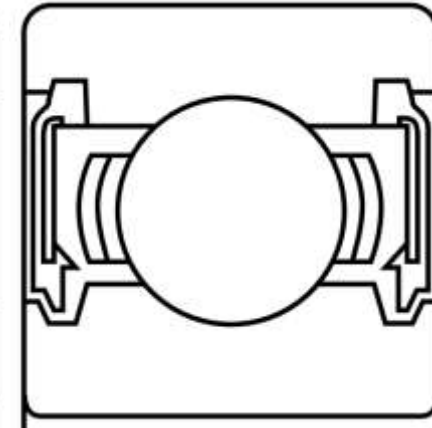

Non-Contact Rubber Sealed Type (VV Type)

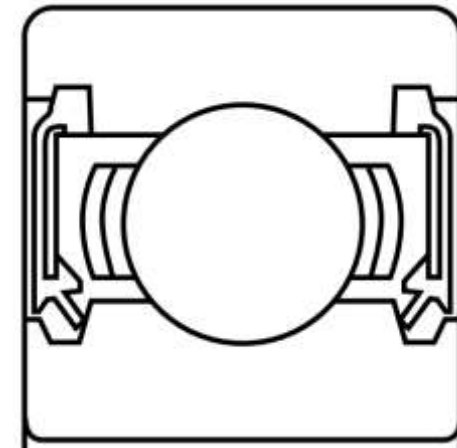

Contact Rubber Sealed Type (DDU Type)

Figs. [NSK 2011]

# Introduction – general information

## 3. Bearing designation

### Suffix – seals and shields

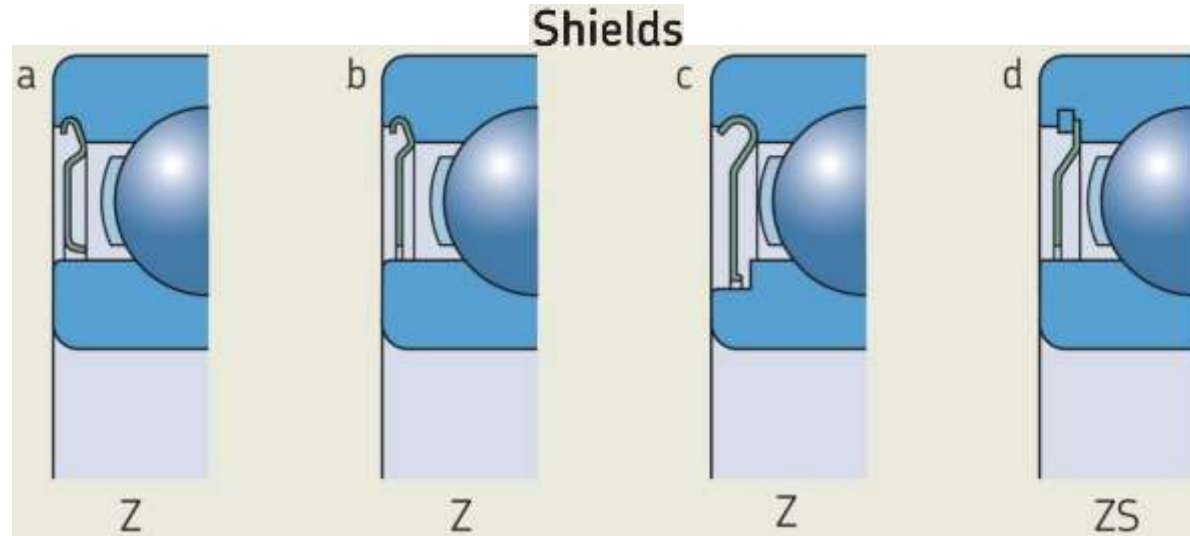

Figs. [SKF 2018]

### Non-contact seal

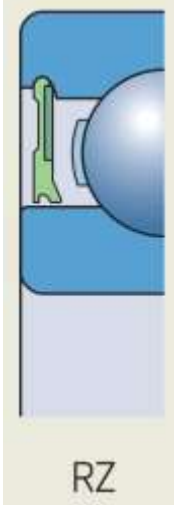

### Low-friction seals, RSL

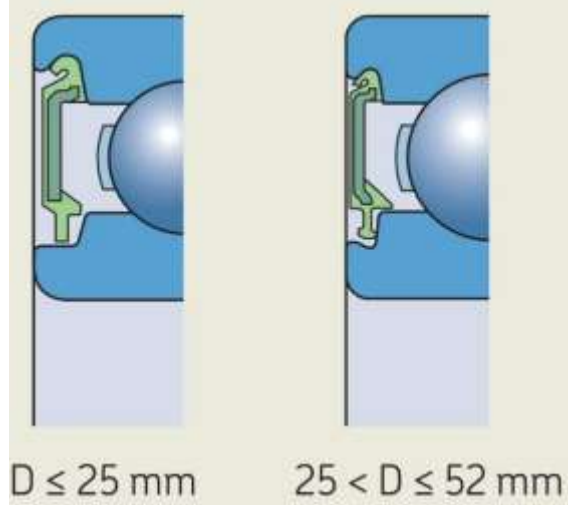

### Low-friction seals, RST

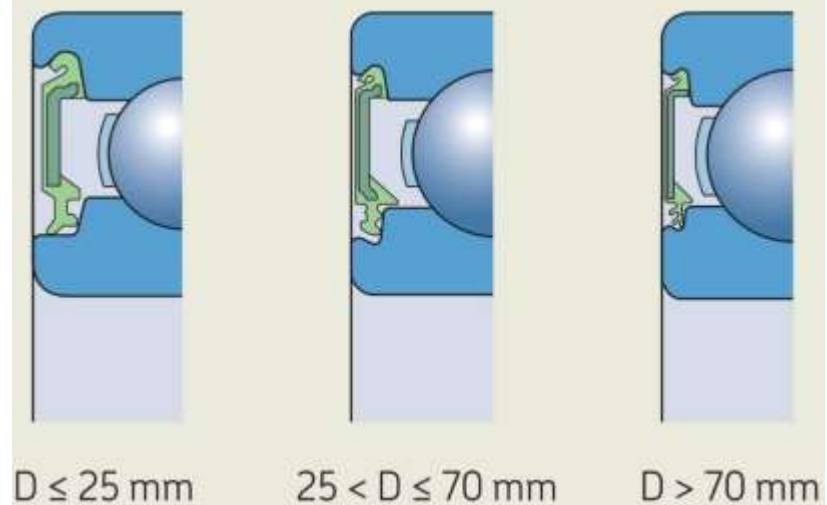

# Introduction – general information

## 3. Bearing designation

### Suffix – seals and shields

Selection guidelines for SKF capping devices

Requirement	Shields	Non-contact seals	Low-friction seals		Contact seals	
	Z, ZS	RZ	RSL	RST	RSH	RS1
Low friction	+++	+++	++	++	o	o
High speed	+++	+++	+++	+	o	o
Grease retention	o	+	+++	+++	+++	++
Dust exclusion	o	+	++	++	+++	+++
Water exclusion						
static	–	–	o	+++	+++	++
dynamic	–	–	o	+	++	+
high pressure	–	–	o	o	+++	o
<b>Symbols:</b>	+++ = best	++ = very good	+ = good	o = fair	– = not recommended	

Fig. [SKF 2018]

# Introduction – general information

## 3. Bearing designation

### Suffix – internal clearance

Bearings are produced with variations in internal radial and axial clearance. As a result of mounting and temperature changes during operation, the internal clearance usually becomes smaller than the value specified. Typically, an interference fit between the bearing, housing and shaft alters the dimensions of the rings and temperature differences cause thermal dimensional changes.

Selecting the appropriate internal clearance for the operating conditions is important due to its influence on bearing fatigue life, vibration and noise or heat generation.

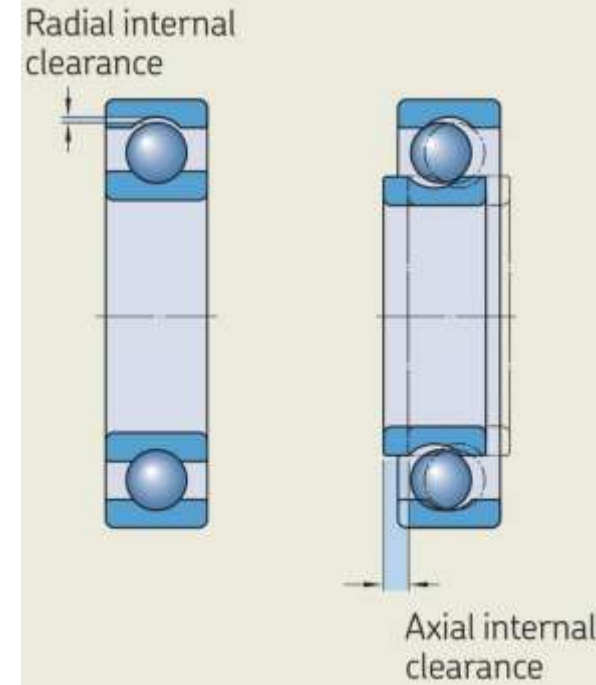

Figs. [SKF 2018]

Internal clearance classes		
ISO clearance class	SKF designation suffix	Internal clearance
–	C1	Smaller than C2
Group 2	C2	Smaller than Normal
Group N	–	Normal
Group 3	C3	Greater than Normal
Group 4	C4	Greater than C3
Group 5	C5	Greater than C4

Dimensional stability		
Stabilization class	Stabilized up to	
	°C	°F
–		
SN	120	250
S0	150	300
S1	200	390
S2	250	480
S3	300	570
S4	350	660

# Introduction – general information

## 3. Bearing designation

### Suffix – internal clearance

Nominal Bore Diameter d (mm)		Clearance									
		C2		CN		C3		C4		C5	
over	incl.	min.	max.	min.	max.	min.	max.	min.	max.	min.	max.
10 only		0	7	2	13	8	23	14	29	20	37
10	18	0	9	3	18	11	25	18	33	25	45
18	24	0	10	5	20	13	28	20	36	28	48
24	30	1	11	5	20	13	28	23	41	30	53
30	40	1	11	6	20	15	33	28	46	40	64
40	50	1	11	6	23	18	36	30	51	45	73
50	65	1	15	8	28	23	43	38	61	55	90
65	80	1	15	10	30	25	51	46	71	65	105
80	100	1	18	12	36	30	58	53	84	75	120
100	120	2	20	15	41	36	66	61	97	90	140
120	140	2	23	18	48	41	81	71	114	105	160
140	160	2	23	18	53	46	91	81	130	120	180
160	180	2	25	20	61	53	102	91	147	135	200
180	200	2	30	25	71	63	117	107	163	150	230
200	225	2	35	25	85	75	140	125	195	175	265
225	250	2	40	30	95	85	160	145	225	205	300
250	280	2	45	35	105	90	170	155	245	225	340
280	315	2	55	40	115	100	190	175	270	245	370
315	355	3	60	45	125	110	210	195	300	275	410
355	400	3	70	55	145	130	240	225	340	315	460
400	450	3	80	60	170	150	270	250	380	350	510
450	500	3	90	70	190	170	300	280	420	390	570

Symbol	Meaning (radial clearance)	
C1	For All Radial Brgs.	Clearance Less than C2
C2		Clearance Less than CN
Omitted		CN Clearance
C3		Clearance Greater than CN
C4		Clearance Greater than C3
C5		Clearance Greater than C4
CC1	For Non-Interchangeable Cylindrical Roller Brgs.	Clearance Less than CC2
CC2		Clearance Less than CC
CC		Normal Clearance
CC3		Clearance Greater than CC
CC4		Clearance Greater than CC3
CC5		Clearance Greater than CC4
MC1	For Extra-Small and Miniature Ball Brgs.	Clearance Less than MC2
MC2		Clearance Less than MC3
MC3		Normal Clearance
MC4		Clearance Greater than MC3
MC5		Clearance Greater than MC4
MC6		Clearance Greater than MC5
CM	Clearance in Deep Groove Ball Bearings for Electric Motors	
CT	Clearance in Cylindrical Roller Bearings for Electric Motors	
CM		
<b>Preload of Angular Contact Ball Bearing</b>		
EL	Extra light Preload	
L	Light Preload	
M	Medium Preload	
H	Heavy Preload	
NSK Symbol	Partially the same as JIS <sup>(5)</sup> /BAS <sup>(6)</sup>	

Fig. [NSK 2011]

Fig. Radial internal clearance of deep groove ball bearings [NSK 2011]

# Introduction – general information

## 3. Bearing designation

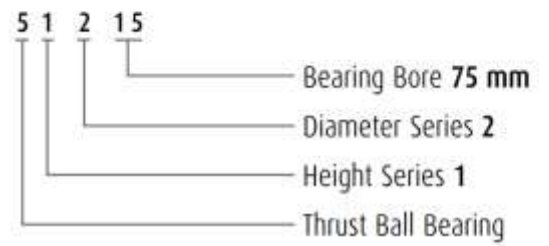
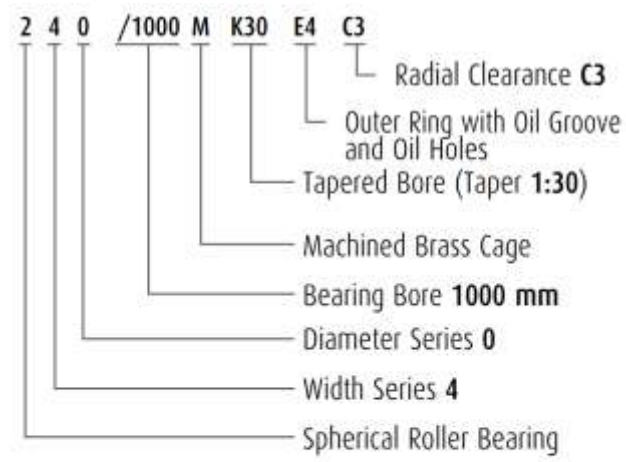
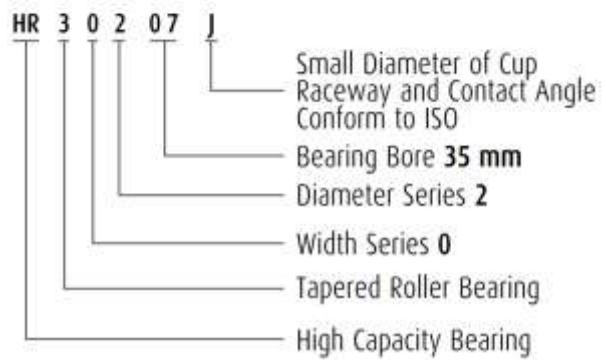
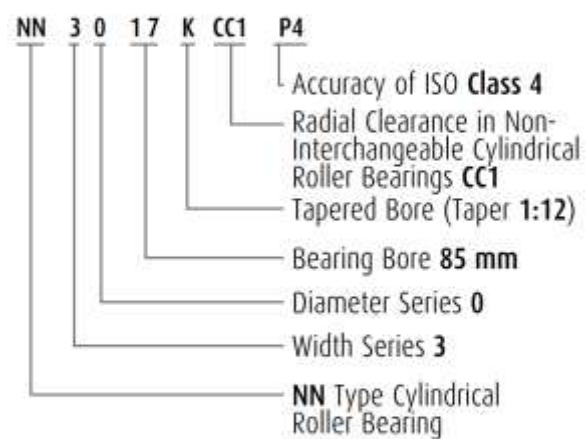
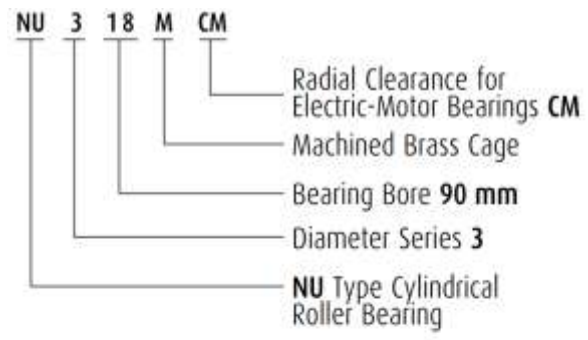
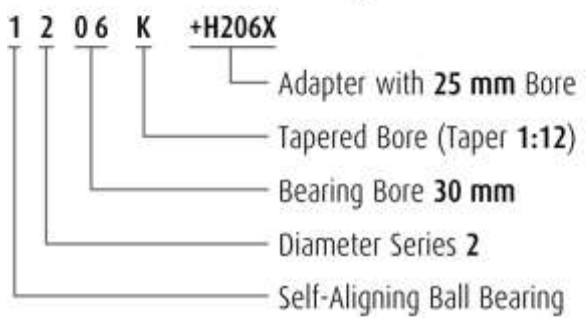
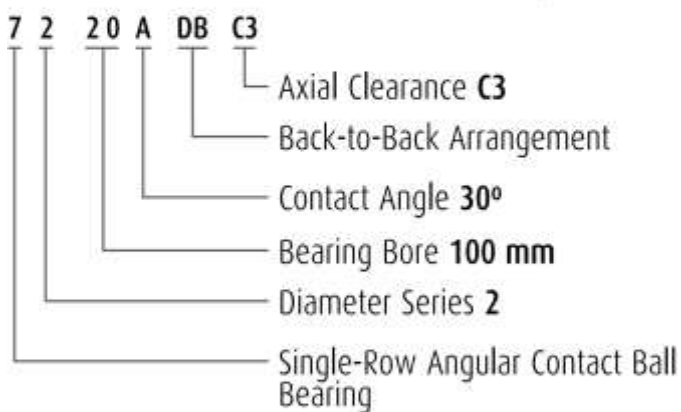
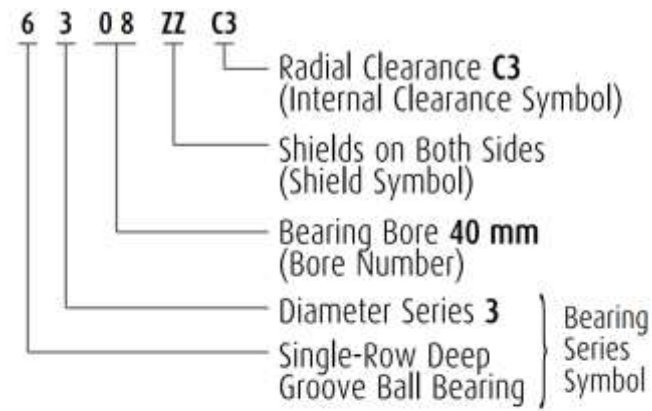

Figs. [NSK 2011]

# Introduction – general information

## 3. Bearing designation

The information presented provides only a basic overview of bearing designation. There are exceptions and detailed guidance depends on the manufacturer. Not all data is included in the bearing designation. For further information refer to for example ISO 355, JIS B 1513 and manufacturers' catalogues.

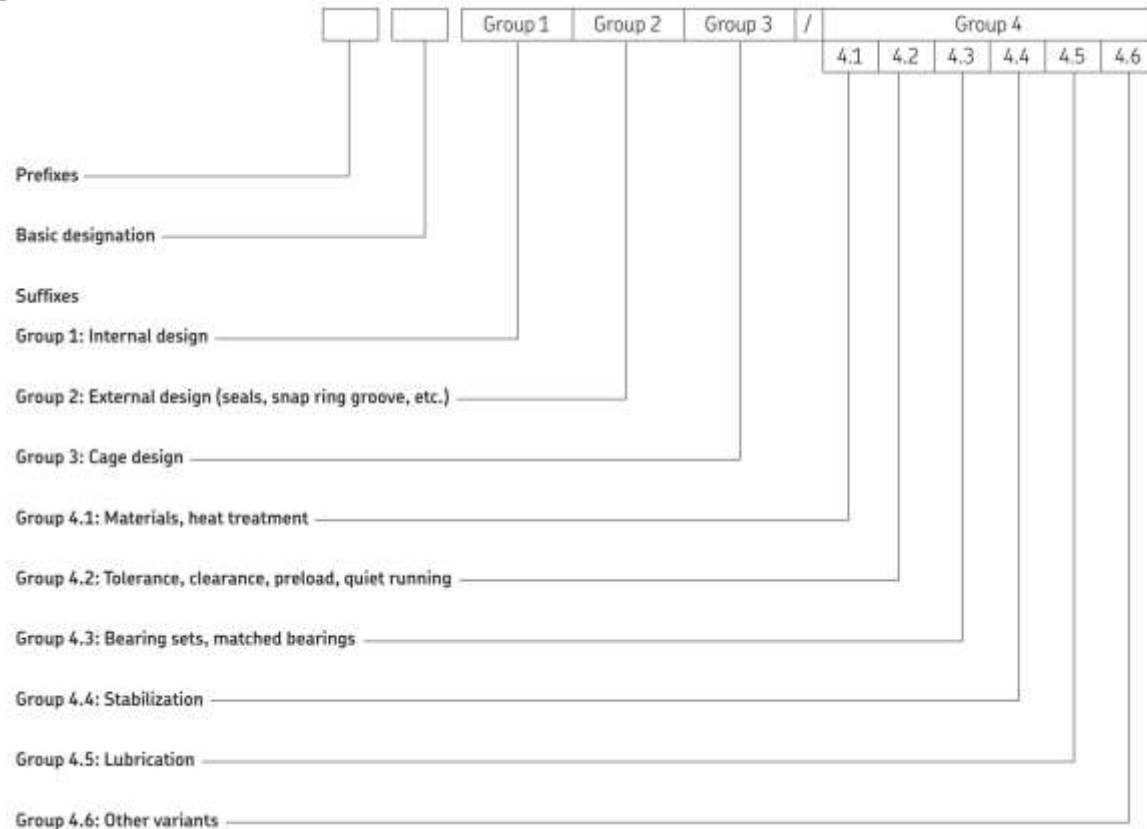

Fig. Detailed designation of a rolling bearing [SKF 2018]

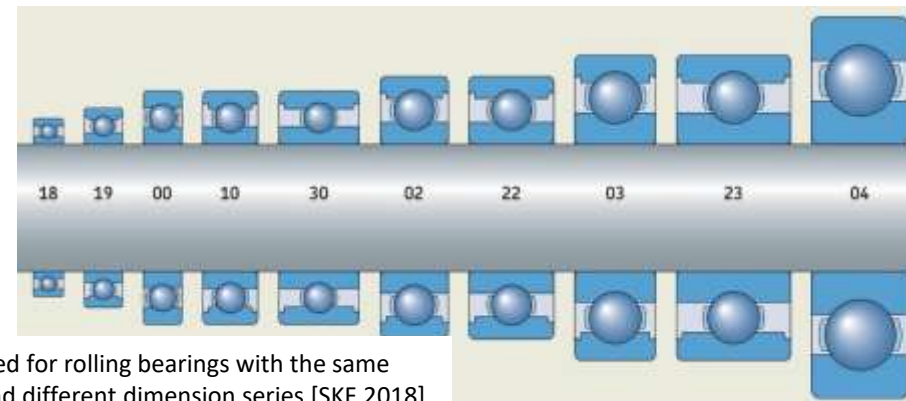

Fig. Space required for rolling bearings with the same bore diameter and different dimension series [SKF 2018]

# Bearing selection

## 1. General information

Bearings are selected during design process. In most cases the shaft geometry is already defined. This means that decisions regarding the number of supports (anchors), their positions and bearing bore diameter have already been made. In addition, the load parameters required for shaft design and bearings selection are determined. However, design is an iterative process. During each iteration knowledge is gained and improvements are made. The design process is completed then assumed properties are achieved.

As mentioned earlier, a single bearing may be used to support a component, in such cases, it is most often a double-row or multi-row bearing, for example a wheel hub bearing in cars. However, the most common solution is to use two supports. Each support typically contains one or two bearings. With a rigid shaft and no preload, this configuration most often forms a statically determinate system. The use of three or more supports is uncommon. Nevertheless, for long shafts and high loads, it may be unavoidable. Such arrangements result in a statically indeterminate system. The calculations are more complex and to achieve higher load capacity proportional to the additional supports, very high manufacturing precision of the housing holes and shaft is required.

The following considerations will therefore focus on cases with two supports.

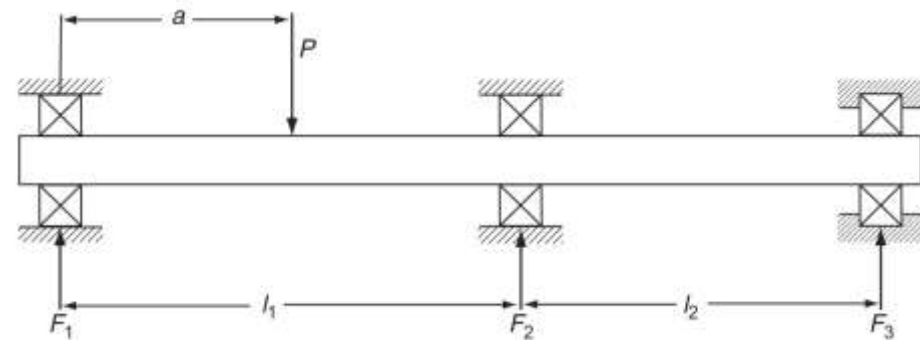

Fig. Arrangement with three supports [Harris (Advanced) 2007]



Fig. Single support arrangement: wheel bearing [https://www.mevotech.com/article/wheel-bearings-and-hubs-101-what-you-need-to-know/]

# Bearing selection

## 2. Two support arrangements

In engineering practice two support arrangements are commonly designed in three configurations:

1. Fixed-free end.
2. Fixed-fixed end (preloaded arrangement).
3. Free-free end.

Certain types of bearings can be used in fixed end support, free end supports and in preloaded arrangements. For simplicity, the following general guidelines may be stated:

- free end – radial load bearings,
- fixed end – double-direction angular contact bearings,
- preloading – single-direction angular contact bearings.

**Note:** One bearing per support is assumed and exceptions apply:

- Free end – double direction angular contact bearings may be used, provided that an appropriate fit is applied to allow axial displacement between the bearing ring and most commonly the housing or more rarely the shaft.
- Fixed end – radial load bearings may be used with additional components, such as a thrust collar, to locate the shaft axially.

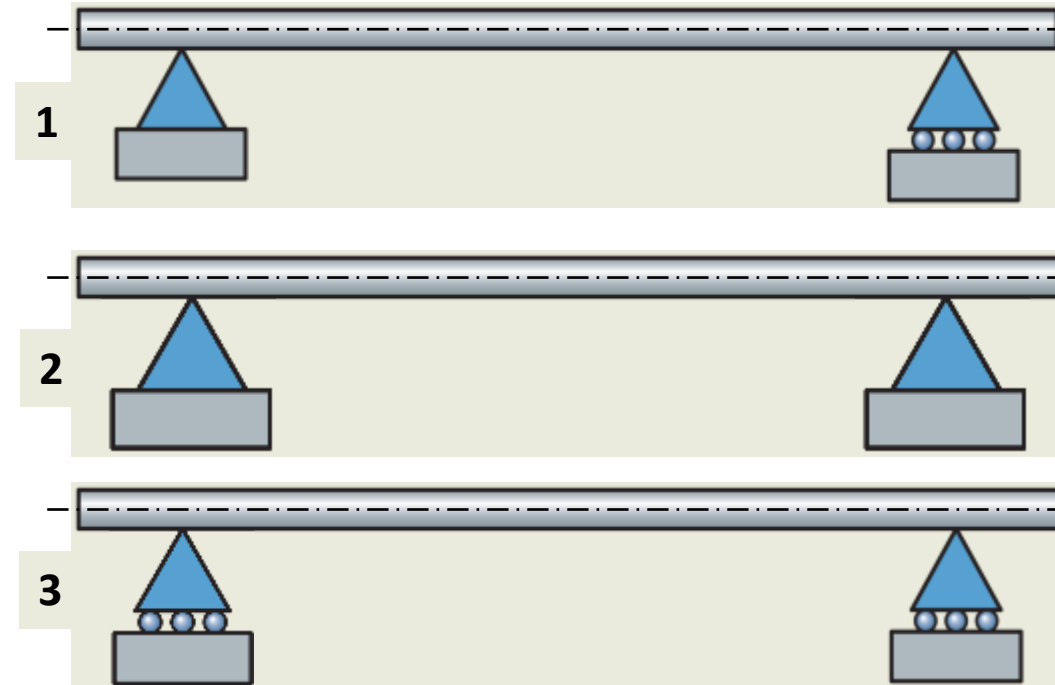

Fig. Modified from SKF 2018

Further details are provided in the table from NSK 2011 presented at the beginning of this presentation and in manufacturers' catalogues.

# Bearing selection

## 2. Two support arrangements

### 2.1. Fixed-free end

This is most common configuration and is used when:

- precise positioning of one end of the shaft is required,
- small to moderate axial forces must be carried by the shaft,
- thermal expansion is significant and must be compensated for (long distance between bearings, large temperature variations),
- dimensional tolerance accumulation must be compensated for.

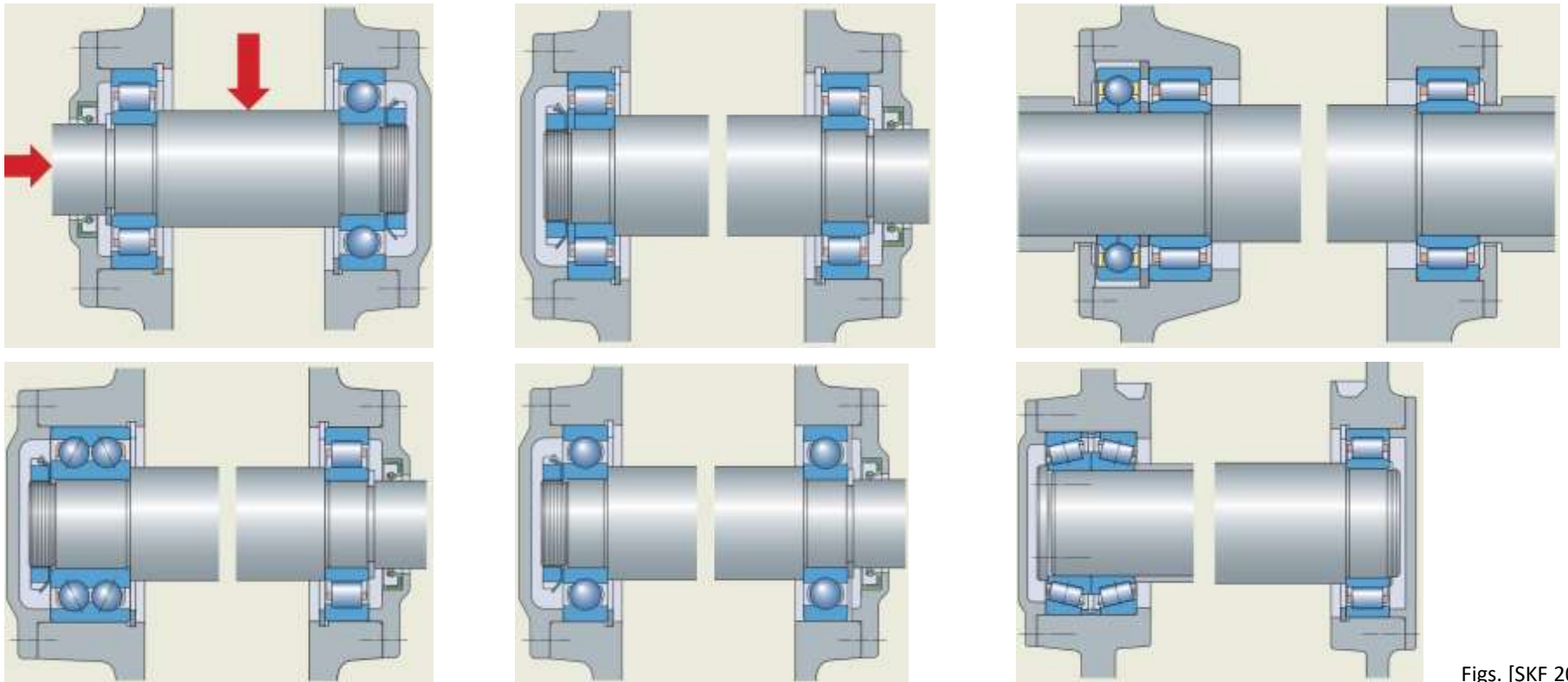

# Bearing selection

## 2. Two support arrangements

### 2.1. Fixed-free end

Examples of fixed-free end arrangements show that the bearing or bearings at one support may be preloaded. In such cases, this support acts as the fixed end and carries the axial load.

A less common solution is the application of preload to the bearings at both supports in a fixed-free end arrangement. In figure from SKF 2018 preload is applied by means of a wave spring. The spring acts on the outer ring of a bearing that is able to move axially, providing light preload to both bearings. This solution is used to reduce noise or prevent damage to the bearings caused by external vibrations during standstill and not intended to carry axial load. It is typically applied in small devices, such as small electric motors.

In the figure from NTN 2024 preload is applied to increase rigidity, accuracy and suppress vibration. This solution is used, for example in milling machines or measuring instruments.

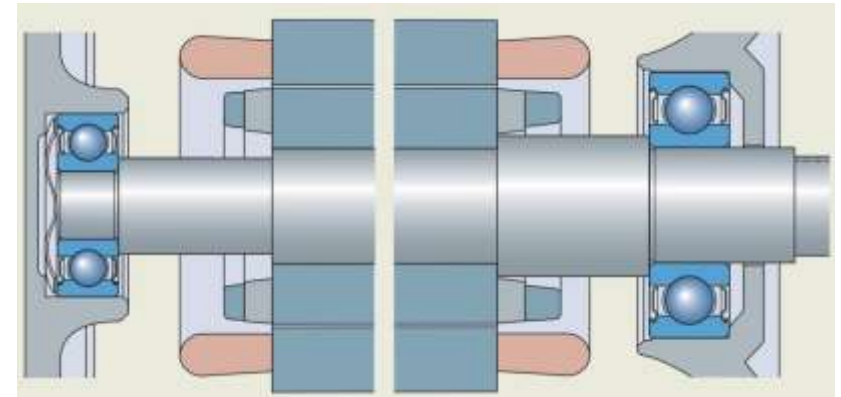

Fig. Preloaded bearings at both supports [SKF 2018]

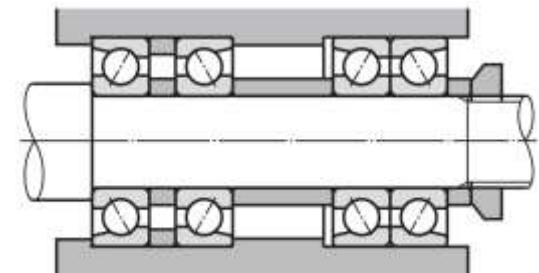
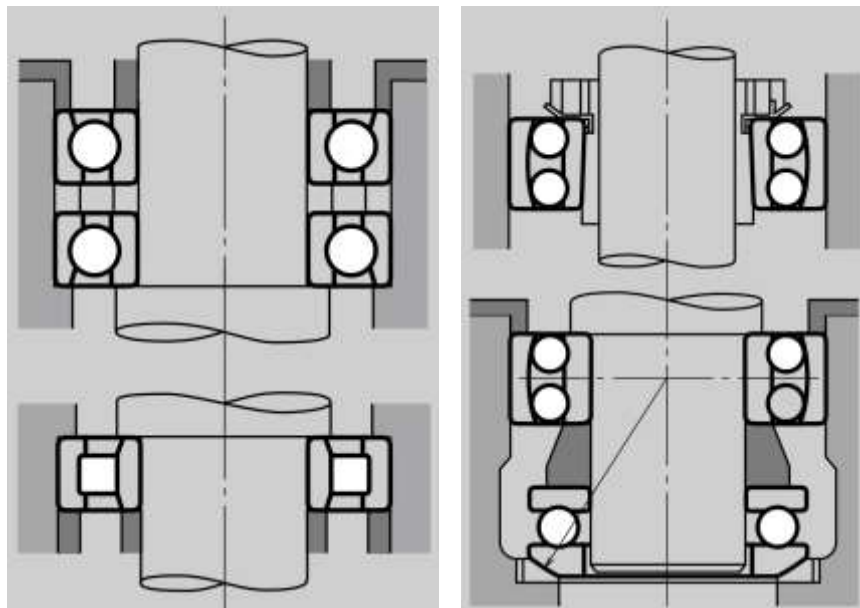

Fig. Preloaded bearings at both supports [NTN 2024]



Figs. Vertical shaft [NSK 2011]

# Bearing selection

## 2. Two support arrangements

### 2.2. Fixed-fixed end (preloaded arrangements)

This configuration is used when:

- the axial force is closed to or greater than the radial force,
- high stiffness of bearings is required,
- resistance to shock loads must be high,
- no internal clearance is permitted.

Special care must be taken with this arrangement. The amount of preload is critical from the perspective of bearing life. Excessive preload overloads the bearings and significantly reduces their service life, while insufficient preload results in only a small number of rolling elements carrying the load, which also greatly shortens bearing life. In addition, even if the correct preload is set during assembly, thermal expansion under operating condition may alter it. This situation occurs most often when the distances between the bearings is significant.

Angular contact ball bearings, tapered roller bearings and spherical roller thrust bearings are mainly used. The bearings applied to the shaft are of the same type but may be of different sizes.



Figs. [www.skf.com]

# Bearing selection

## 2. Two support arrangements

### 2.2. Fixed-fixed end (preloaded arrangements)

Angular single row bearing can carry axial load only in one direction. For proper work preload is necessary thus to applied it at least two bearings in opposite position to each other must be used. Two possible solution are obtained: O arrangement (back-to-back or indirect mounting ) and X arrangement (face-to-face or direct mounting).

O and X arrangements of angular contact bearings differ not only in the method of mounting and the way preload is applied, but also in how the load is transferred from the shaft to the housing.

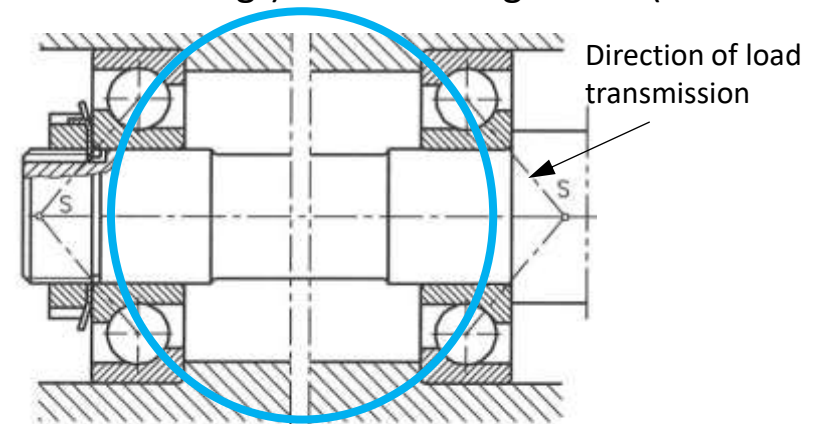

Fig. O arrangement [Mazanek 2005]

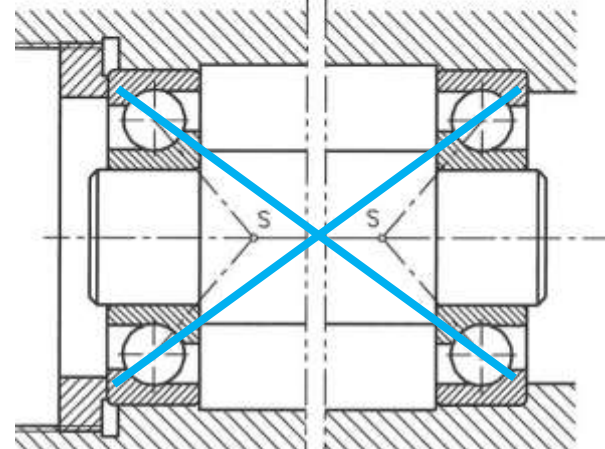

Fig. X arrangement [Mazanek 2005]

# Bearing selection

## 2. Two support arrangements

### 2.2. Fixed-fixed end (preloaded arrangements)

#### *Properties of the O arrangement (back-to-back):*

- better resistance to (tilting) moment loads due to the greater distance between pressure centres compared with the X arrangement. This is especially important when the distance between the bearings is relatively small,
- greater thermal expansion of shaft than of the housing results in a decrease in preload,
- greater stiffness compared with X arrangements,
- high manufacturing accuracy of the housing and shaft is required due to the very small tolerance for misalignment.

#### *Properties of the X arrangement (face-to-face):*

- greater tolerance to misalignment than O arrangements,
- greater thermal expansion of the shaft than housing results in an increase in preload,
- the inner ring has an interference fit which is usually desirable if the inner ring is non-stationary.

#### Back-to-back

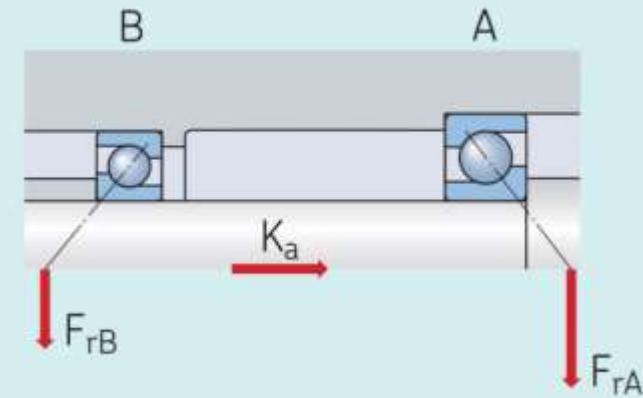

#### Face-to-face

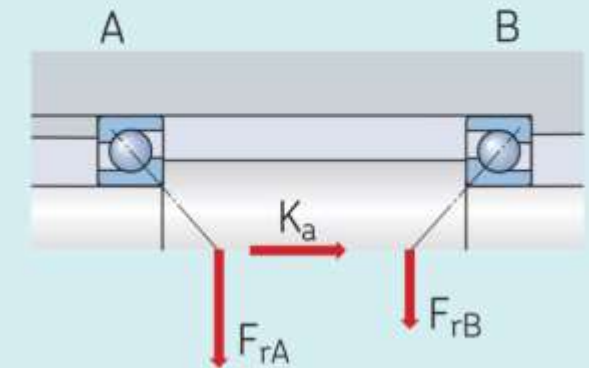

Fig. [SKF 2018]

# Bearing selection

## 2. Two support arrangements

### 2.3. Free-free end

The shaft has the possibility of limited axial movement in both directions. A situation in which the clearance  $s$  becomes zero, for example due to thermal expansion, must be avoided as this would cause abnormal loading that could result in premature bearings wear or distortions. This configuration can support only limited axial force.

This configuration is used when:

- the position of the shaft is determined by a component mounted on the shaft and must remain fixed or be adapted regardless of thermal expansion or dimensional tolerances, for example a gear in a double-helical gearbox,
- interference fits on both the inner and outer rings are required, this is applicable to cylindrical roller or needle bearings.

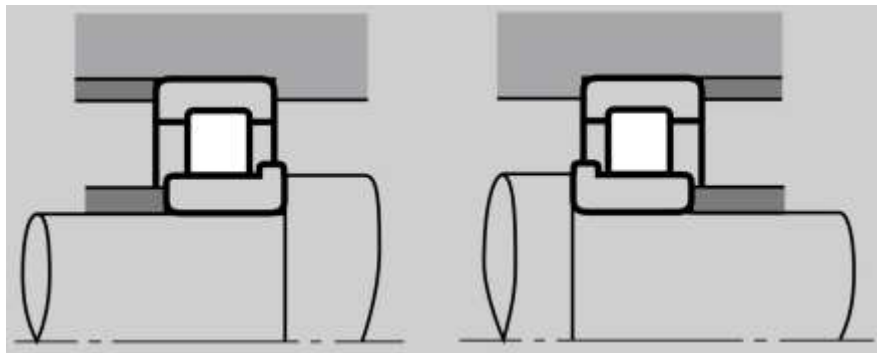
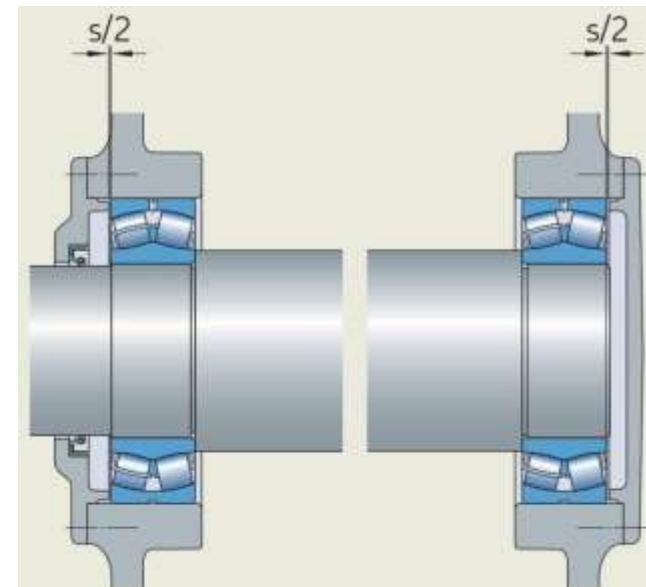
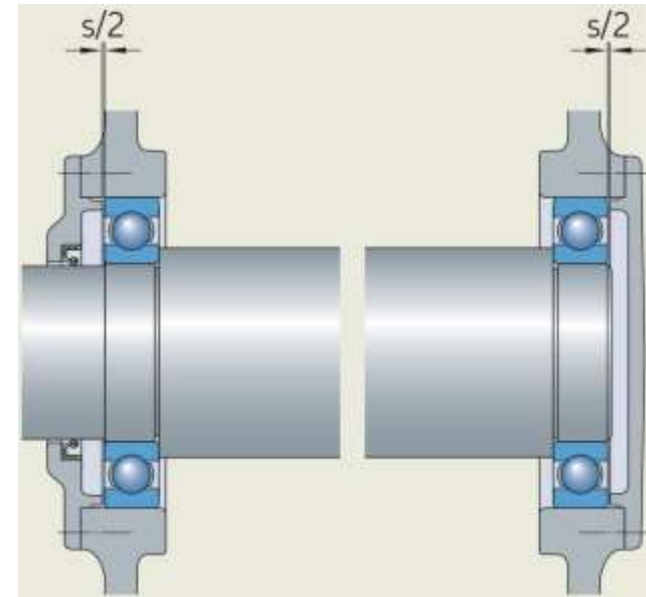

Fig. [NSK 2011]



Figs. [SKF 2018]

# Bearing selection

## 3. Selection criteria

The process of bearing selection to meet the required performance and operating conditions is multifactorial. **Only limited information will be provided in this section.** More details can be found in manufacturers' catalogues; specialist literature and some manufacturers provide software for bearing selection and direct support.



-  Performance and operating conditions
-  Bearing type and arrangement
-  Bearing size
-  Lubrication
-  Operating temperature and speed
-  Bearing interfaces
-  Bearing execution
-  Sealing, mounting and dismounting

Fig. Modified from SKF 2018

# Bearing selection

## 3. Selection criteria

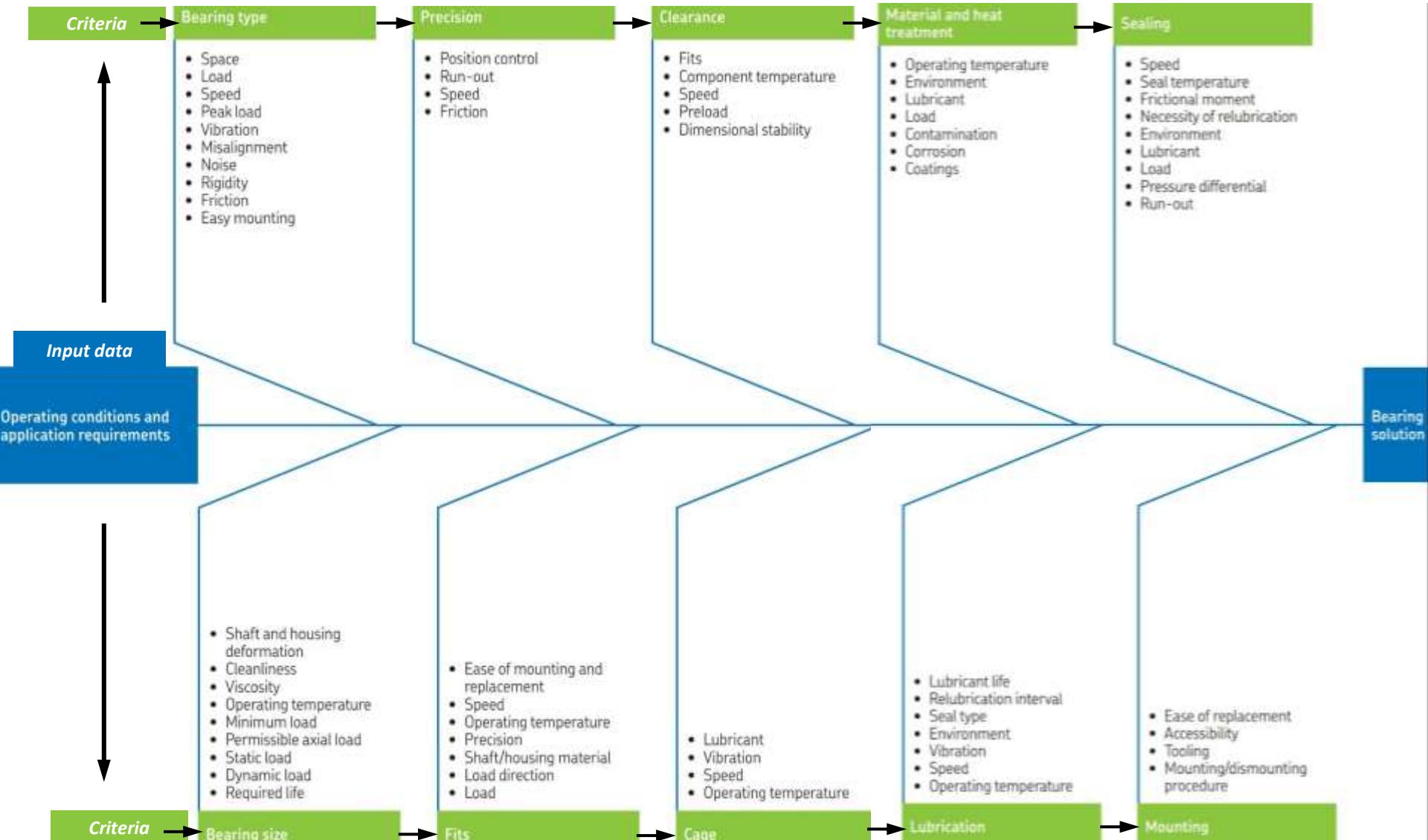

Fig. Modified from SKF 2018

# Bearing selection

## **3. Selection criteria**

### **3.1. Bearing type**

The type of bearing can be chosen based on solutions used in the same or similar devices. For the improvement of an existing design, the development of a new type of device or the achievement of ultimate performance all possible types of bearing should be considered. Based on weighted selection criteria the range of suitable bearing types should then be narrowed.

The bearing type defines the following properties:

- load capacity (type and direction of load, resistance to shock loads, space requirements and load to space ratio, rigidity and the possibility of preloading),
- precision (friction, noise and vibration, maximum speed and accuracy of motion),
- misalignment (tolerance of static and dynamic misalignment),
- easy of mounting (possibility of bearing division),
- lubrication (possibility of applying internal seals and shields).

More than one bearing can be used in a support to achieve specific performance characteristics.

# Bearing selection

## 3. Selection criteria

### 3.1. Bearing type

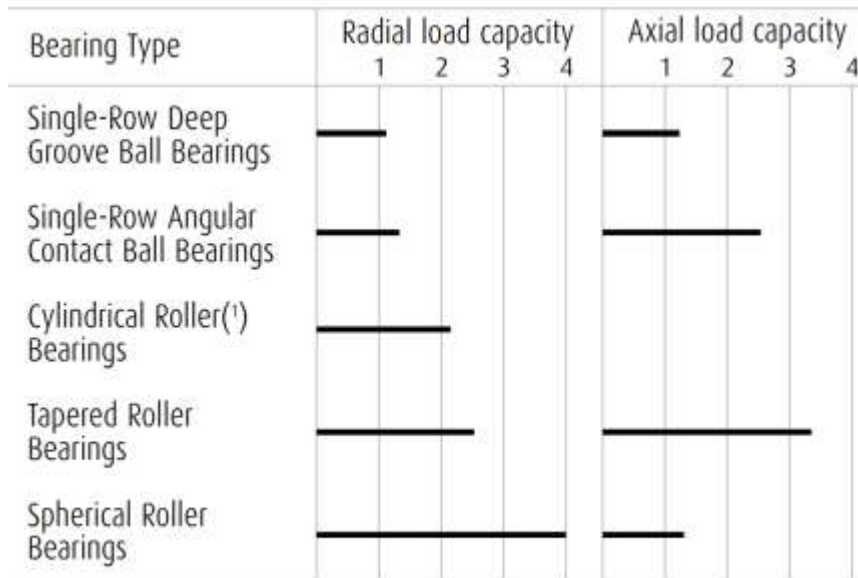

Note(¹) The bearings with ribs can take some axial loads.

Figs. [NSK 2011]

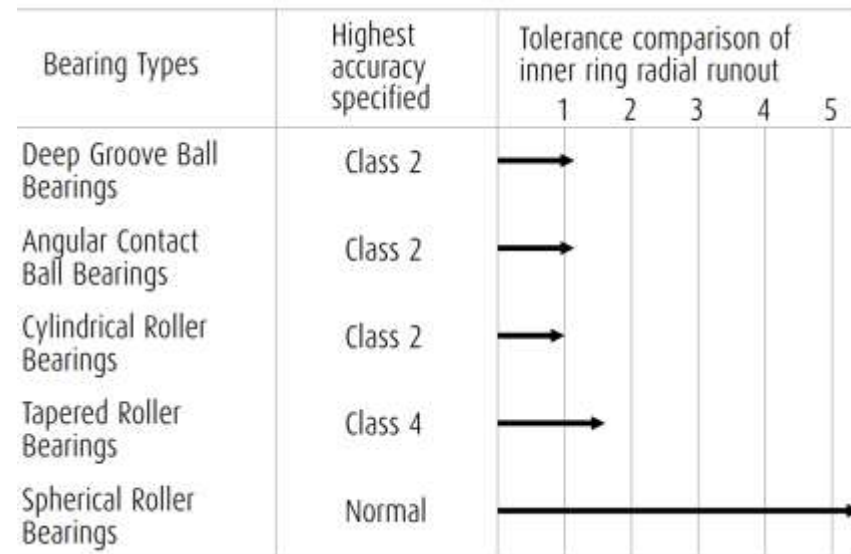
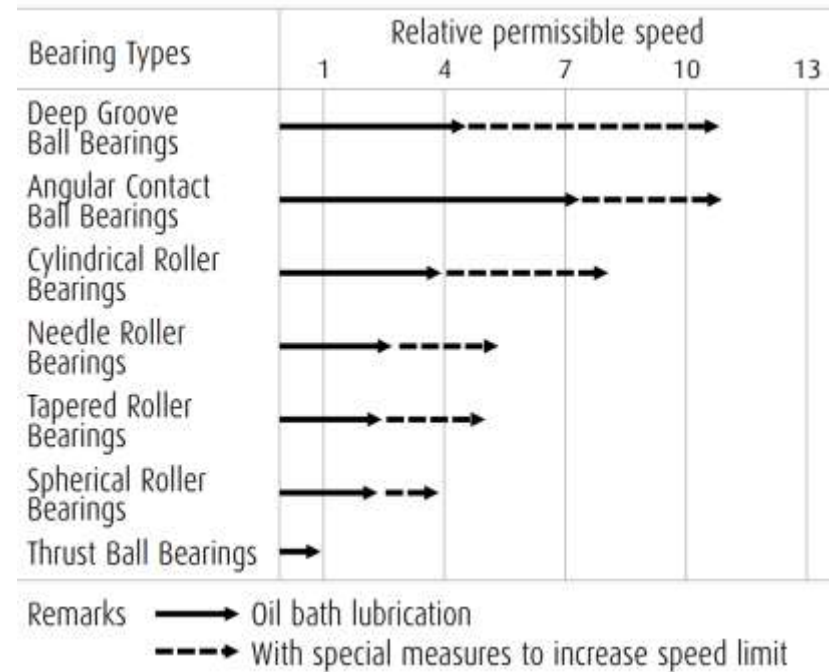

# Bearing selection

## 3. Selection criteria

### 3.2. Bearing size – general information

On this stage bearings type and hole diameter of bearings are determined (it is depend on the designing strategy). Designer select bearing size, more precise has at his disposal the following choice:

- dimension series of bearing, that is outside diameter and width,
- number of rows in bearing (depend on the type of bearing),
- number of bearings (depend on the type of bearing).

Bearing size determines mainly minimum and maximum dynamic load, maximum static load and at some point, maximum speed.

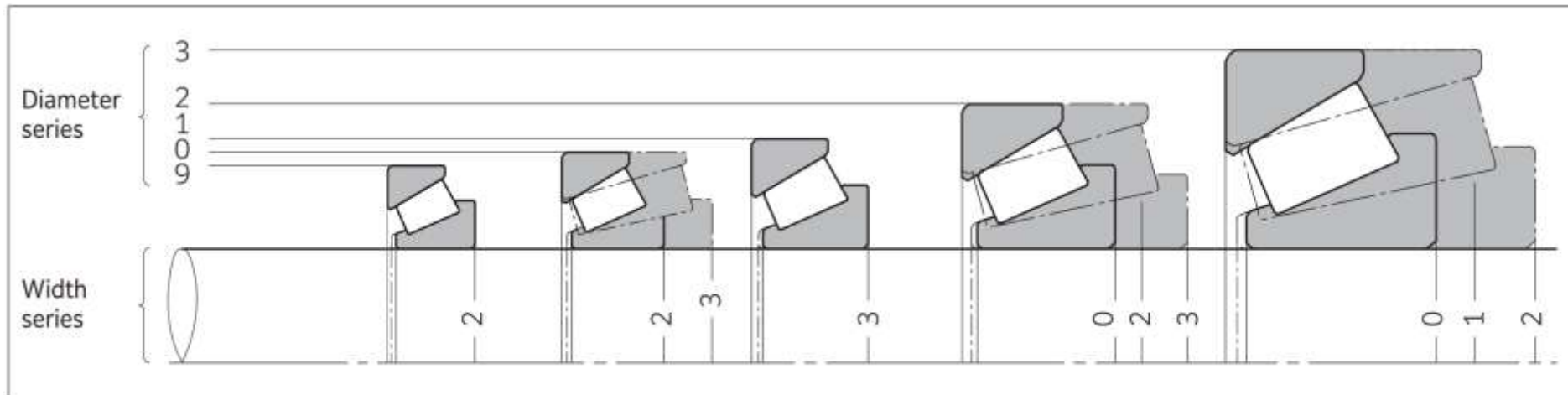

Fig. 5.5 Dimension series for tapered roller bearings (based on JIS B 1534) [NTN 2024]

# Bearing selection

## 3. Selection criteria

### 3.2. Bearing size – general information

In general, the task of an engineer at this stage is to select an appropriate size of bearing that will be able to carry the working load under operating conditions for a required period of time (service life). There is an almost infinite combination of loads (characterised by direction, sense and magnitude which may vary over time), operating conditions (rotational speed that may change in magnitude and direction over time including standstill, temperature etc.) and required service life (understood as the required operating hours, number of revolutions or distance in kilometres).

In catalogues the data tables provide two basic parameters that are essential for the selection of an appropriate bearing size: the **basic load ratings** and the **limiting speed**. Owing to the almost countless combinations of load, speed and required life it is not possible to provide data for all cases. The basic load ratings and limiting speed are determined under specific conditions defined in standards and adopted by manufacturers. Based on empirical and theoretical research a models have been developed that enables the required bearing life to be determined by adjusting real operating conditions to those specified in the catalogues.

The **limiting speed** provided in catalogues is usually given as more than one value in revolutions per minute, as it is specified for different operating conditions. The maximum speed is limited by the bearing construction (such as the cage, seals or strength of the rolling elements) and by temperature (which depends on lubrication conditions, temperature of ambient components and load). More details can be found in manufacturers' catalogues.

Fig. [SKF 2018]

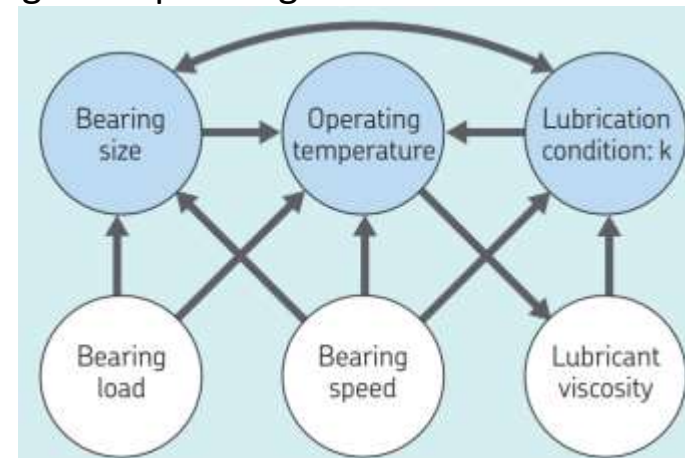

# Bearing selection

## 3. Selection criteria

### 3.2. Bearing size – general information

The **basic load ratings** are provided as two parameters: *static load rating* and *dynamic load rating*.

#### **Static load rating $C_0$**

The static load rating is defined as the force, expressed in newtons, that does not cause permanent plastic deformation of the raceway and rolling elements exceeding  $0.0001 D_k$ , where  $D_k$  is the diameter of the rolling elements. Based on experience, this level of deformation does not negatively affect the bearing's service life or accuracy.

Static conditions occur when:

- there is no rotation or rotational speed does not exceed 10 rpm,
- impulsive (shock) loads are present.

Under these conditions, bearings must be checked with respect to static load.

#### **Dynamic load rating $C$**

The dynamic load rating is defined as the force, expressed in newtons, that will cause fatigue failure in the form of spalling (flaking) in 10% of a group of seemingly identical bearings when the number of revolutions reaches one million. Testing is carried out under ideal conditions. No manufacturing or assembly defects are present, lubrication is adequate, and both speed and load are constant. The outer ring is stationary, while the inner ring is the rotating component.



Fig. Spalling (flaking) [NSK 2011]

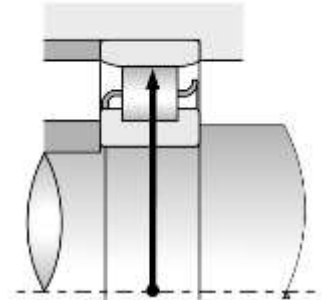

Fig. Load during the determination of the static load rating [NSK 2011]

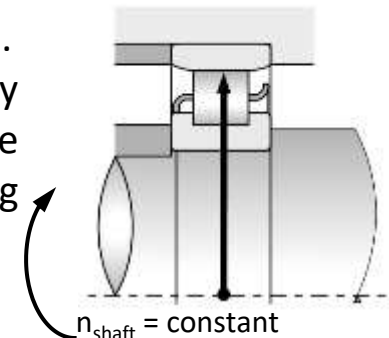

Fig. Load during the determination of the dynamic load rating [NSK 2011]

# Bearing selection

## 3. Selection criteria

### 3.2. Bearing size – general information

#### Equivalent bearing loads

The force applied during the determination of the *static load rating*  $C_0$  and the *dynamic load rating*  $C$  has a constant direction and magnitude. For bearings with a contact angle  $\alpha = (0^\circ; 45^\circ)$  the applied load is a purely radial force, while for bearings with a contact angle  $\alpha = (45^\circ; 90^\circ)$  it is a purely axial force.

The direction of the applied force during testing is the same for radial bearings ( $\alpha = 0^\circ$ ) and thrust bearings ( $\alpha = 90^\circ$ ). For angular contact bearings however, the test load direction differs from that occurring during operation, where the bearing is subjected to a combination of radial and axial loads acting simultaneously.

In practice, real load conditions are most often different from those used during the determination of basic load ratings. To relate real operating loads to the conditions used in testing, **equivalent bearing loads** are introduced (Fig.). The equivalent bearing load is theoretical load that has the same effect on bearing life as the actual load but has a constant direction and magnitude. It is a purely radial load for bearings with a contact angle  $\alpha = (0^\circ; 45^\circ)$  and a purely axial load for bearings with a contact angle  $\alpha = (45^\circ; 90^\circ)$ .

Equivalent bearing loads are determined for both static  $C_0$  and dynamic  $C$  load ratings as the **equivalent static bearing load**  $P_0$  and **equivalent dynamic bearing load**  $P$ .

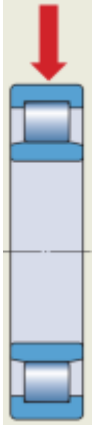

Fig. Pure radial load – radial bearing [SKF 2018]

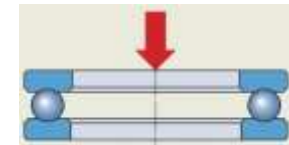

Fig. Pure axial load – thrust bearing [SKF 2018]

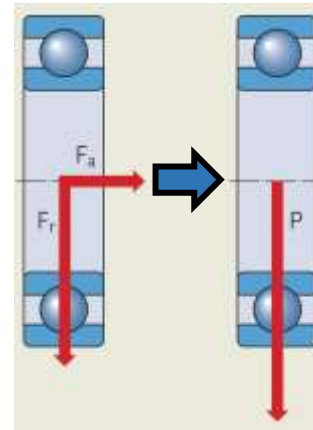

Fig. Real radial  $F_r$  and axial  $F_a$  load converted to equivalent bearing radial load  $P$  [SKF 2018]

# Bearing selection

## 3. Selection criteria

### 3.2. Bearing size – general information

#### Equivalent bearing loads

##### 1. Operation at constant speed and load

In the case of operation at constant speed and load, changes are required only for angular contact bearings. The combined radial and axial forces are replaced by a single equivalent load acting in either the radial or axial direction, according to the equation below.

##### a) Equivalent static bearing load $P_o$

- radial bearings

$$P_o = F_r$$

- angular contact bearings

$$P_o = V X_o F_r + Y_o F_a$$

- thrust bearings

$$P_o = F_a$$

where:

$P_o$  – equivalent static bearing load in N or kN,

$F_r$  – constant radial load in N or kN,

$F_a$  – constant axial load in N or kN,

$V$  – rotation factor,

$V = 1$  – inner ring rotates (as during load rating determination),

$V = 1,2$  – outer rings rotates (the length of the loaded raceway on the inner ring is smaller than in the case of a rotating outer ring),

$X_o$  – radial load factor (value depends on the bearing type and is given in the manufacturer's catalogue),

$Y_o$  – axial load factor (value depends on the bearing type and is given in the manufacturer's catalogue).

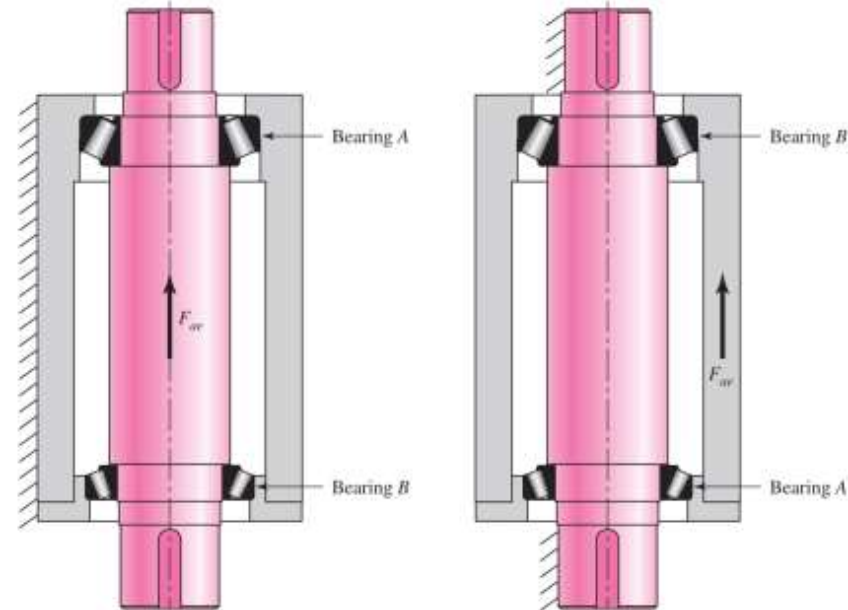

Fig. [Budynas 2008]

# Bearing selection

## 3. Selection criteria

### 3.2. Bearing size – general information

#### Equivalent bearing loads

##### 1. Operation at constant speed and load

##### b) Equivalent dynamic bearing load $P$

- radial bearings

$$P = F_r$$

- angular contact bearings

$$P = V X F_r + Y F_a$$

- thrust bearings

$$P = F_a$$

where:

$P$  – equivalent dynamic bearing load in N or kN,

$F_r$  – constant radial load in N or kN,

$F_a$  – constant axial load in N or kN,

$V$  – rotation factor,

$V = 1$  – inner ring rotates (as during load rating determination),

$V = 1,2$  – outer rings rotates (the length of the loaded raceway on the inner ring is smaller than in the case of a rotating outer ring),

$X$  – radial load factor (value depends on the bearing type and is given in the manufacturer's catalogue),

$Y$  – axial load factor (value depends on the bearing type and is given in the manufacturer's catalogue).

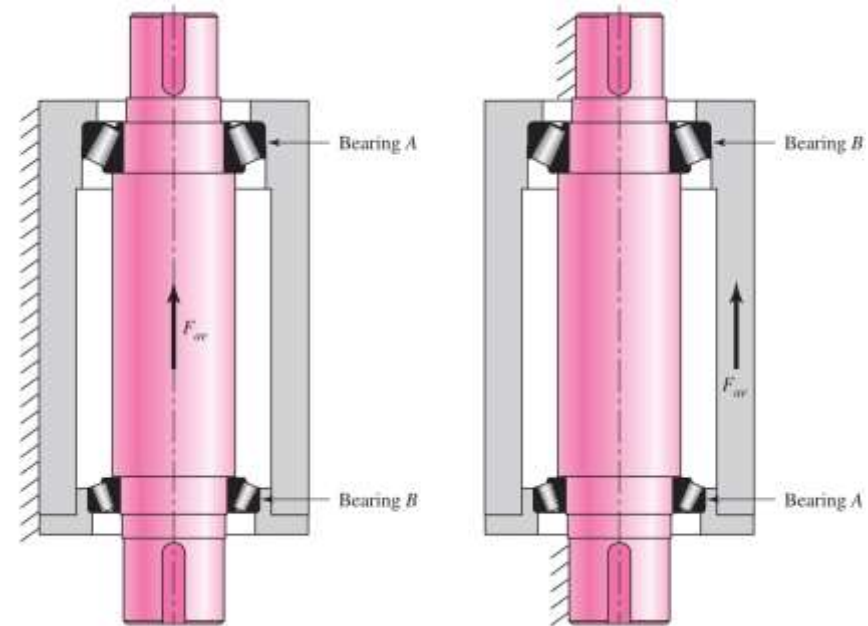

Fig. [Budynas 2008]

# Bearing selection

## 3. Selection criteria

### 3.2. Bearing size – general information

#### Equivalent bearing loads

##### 1. Operation at constant speed and load

The values of parameters  $X$  ( $X_0$ ) and  $Y$  ( $Y_0$ ) depend on the bearing type and its construction.

Figure shows the diagram for a ball bearing. On the x-axis is  $\frac{F_a}{V F_r}$  and on the y-axis is  $\frac{P}{V F_r}$ . The diagram can be interpreted as influence of axial load on the equivalent bearing radial load.

At low axial loads, the axial force has no noticeable influence, and the results may be approximated by a horizontal line. Beyond a certain point, as the axial load increases, the resulting values also rise. This second region may also be approximated by a straight line.

The intersection of these two lines indicates the point at which the axial load begins to have an observable influence on the equivalent radial load and, consequently, on bearing life. This boundary value is denoted by  $e$  and its value is given in manufacturers' catalogues. Based on the diagram it may be concluded that:

$$\frac{F_a}{V F_r} \leq e \rightarrow X = 1, Y = 0 \rightarrow P = V F_r$$

$$\frac{F_a}{V F_r} > e \rightarrow P = V X F_r + Y F_a$$

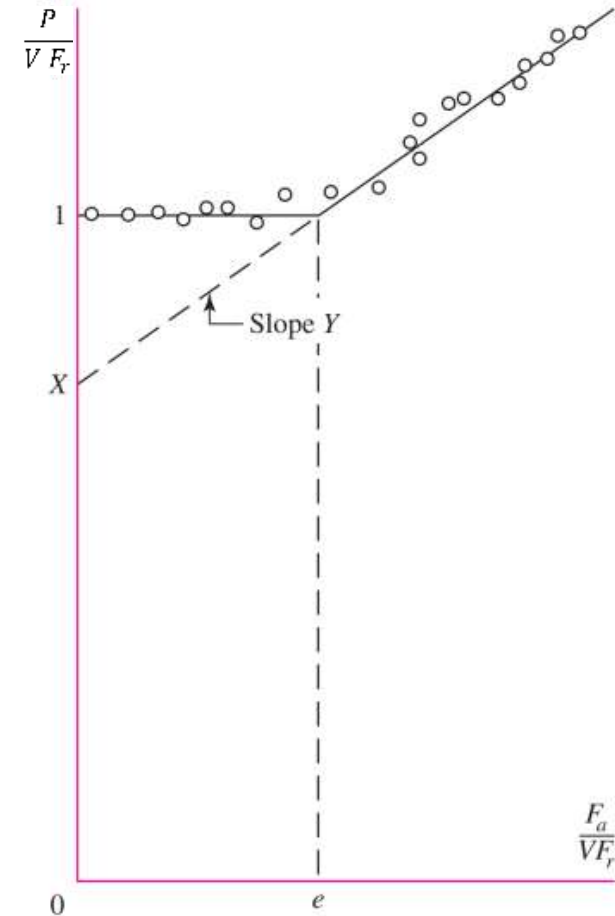

Fig. [Budynas 2008]

# Bearing selection

## 3. Selection criteria

### 3.2. Bearing size – general information

#### Equivalent bearing loads

##### 1. Operation at constant speed and load

Once again, we consider the diagram and the two lines that approximate real results.

The equation of straight line can be written as linear function of the form:

$$y = a x + b$$

If the linear function is a constant function (a horizontal line) it has the form:

$$y = b$$

According to the figure  $y = \frac{P}{V F_r}$  and  $b = 1$  thus:

$$1 = \frac{P}{V F_r} \rightarrow P = V F_r \quad \text{for} \quad \frac{F_a}{V F_r} \leq e$$

The second line is approximated by a function with a non-zero slope  $a \neq 0$ . Based on the figure it can be written as:

$$\begin{array}{ccccccc} y & = & a & x & + & b & \\ \downarrow & & \downarrow & \downarrow & & \downarrow & \\ \frac{P}{V F_r} & = & Y & \frac{F_a}{V F_r} & + & X & \end{array} \rightarrow P = V X F_r + Y F_a \quad \text{for} \quad \frac{F_a}{V F_r} > e$$

The equations for the equivalent bearing load were derived.

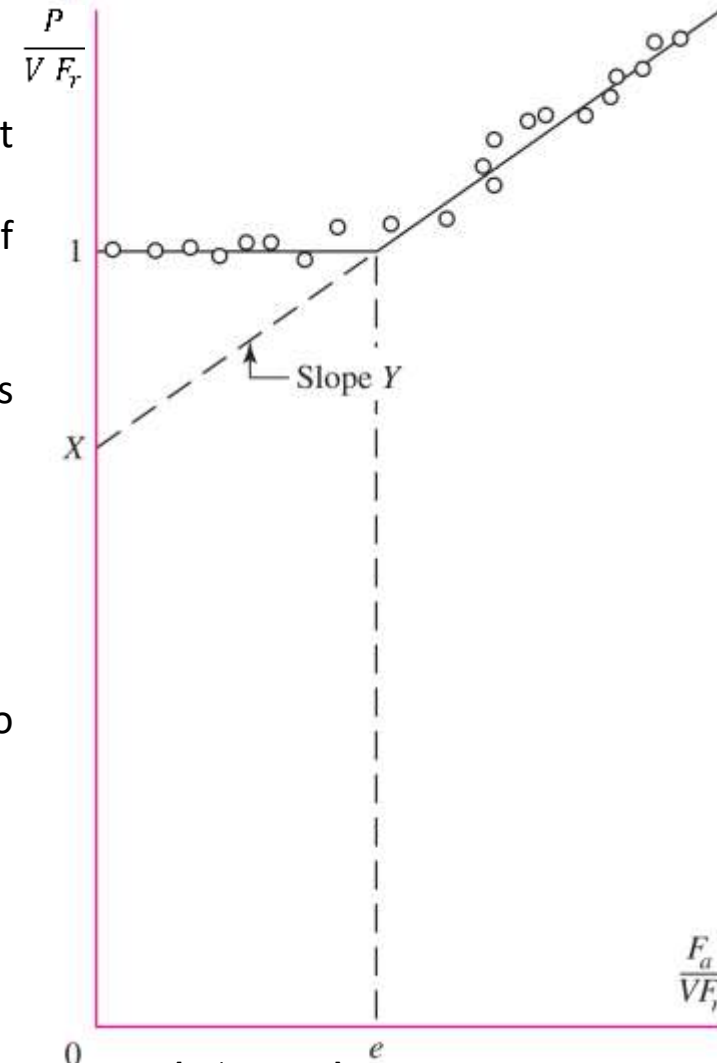

Fig. [Budynas 2008]

# Bearing selection

## 3. Selection criteria

### 3.2. Bearing size – general information

#### Equivalent bearing loads

##### II. Operation at variable speed and load

Then load is varying, that is magnitude, direction or sense is change in time, or rotational speed is not constant it must be consider. In formula on equivalent bearing load forces  $F_r$  and  $F_a$  are constant values. It can be distinguished common situation:

- i. constant load with occasional and significant peaks,
- ii. load is changing during time,
- iii. load and speed is changing during time,
- iv. forces with constant and changing direction.

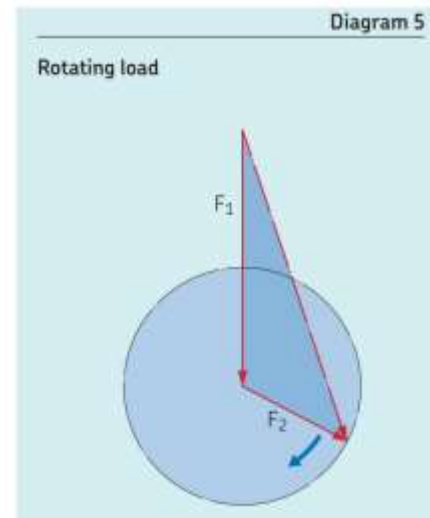
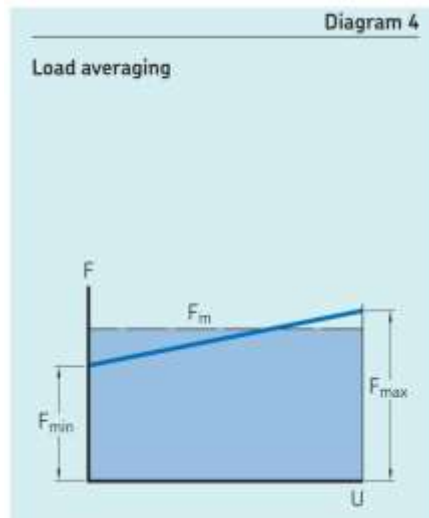

# Bearing selection

## 3. Selection criteria

### 3.2. Bearing size – general information

#### Equivalent bearing loads

##### II. Operation at variable speed and load

When rotational speed is steady and load vary due to principle of machine operation an equivalent dynamic bearing load  $P$  may be obtain using a load factor  $f_w$  ( $f_b$  or  $f_z$ ). It is also applied when information about the load characteristics is limited or when this is a preliminary iteration of the bearing size assessment.

$$P = f_w P_t$$

where:

$P$  – equivalent dynamic bearing load in N or kN,

$f_w$  – load factor,

$P_t$  – theoretical (design) equivalent dynamic bearing load in N or kN,

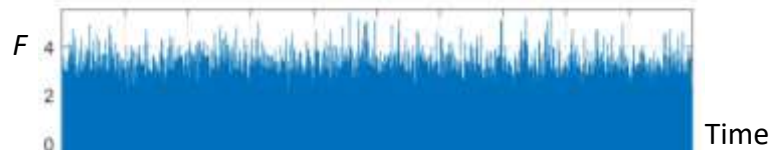

Table 4.6 Chain or belt factor  $f_b$  Fig. [NTN 2024]

Chain or belt type	$f_b$
Chain (single)	1.2 to 1.5
V-belt	1.5 to 2.0
Timing belt	1.1 to 1.3
Flat belt (w / tension pulley)	2.5 to 3.0
Flat belt	3.0 to 4.0

Table 4.1 Load factor  $f_w$  Fig. [NTN 2024]

Amount of shock	$f_w$	Machine application examples
Very little or no shock	1.0 to 1.2	Electric machines, machine tools, measuring instruments.
Light shock	1.2 to 1.5	Railway vehicles, automobiles, rolling mills, metal working machines, paper making machines, printing machines, aircraft, textile machines, electrical units, office machines.
Heavy shock	1.5 to 3.0	Crushers, agricultural equipment, construction equipment, cranes.

Table 4.2 Gear factor  $f_z$  Fig. [NTN 2024]

Gear type	$f_z$
Precision ground gears (Pitch and tooth profile errors of less than 0.02 mm)	1.05 to 1.1
Ordinary machined gears (Pitch and tooth profile errors of less than 0.1 mm)	1.1 to 1.3

# Bearing selection

## 3. Selection criteria

### 3.2. Bearing size – general information

#### Equivalent bearing loads

#### II. Operation at variable speed and load

##### i. Constant load with occasional and significant peaks

The force-time graph illustrates a situation in which force has a constant value, with occasional peaks of significantly higher magnitude. These peaks occur intermittently and usually do not noticeably change the mean force value. Although their duration is very short, they may lead to permanent deformation of bearing components.

For this reason, the load must be compared with the static load rating  $C_0$ . Precise information about the magnitude of peak loads is often unavailable. In such cases, an equivalent static bearing load  $P_0$  may be adjusted by a peak load factor  $f_p$  ( $f_s$  or  $s_0$ ):

$$P_0 = f_w P_{t0}$$

thus:

$$C_0 \leq f_w P_{t0}$$

where:

$P_0$  – equivalent static bearing load in N or kN,

$f_w$  – load factor,

$P_t$  – theoretical (design) equivalent dynamic bearing load in N or kN,



Guideline values for the static safety factor $s_0$ – for continuous and/or occasional loads – ball bearings				
Certainty of load level	Continuous motion Permanent deformation acceptance			Infrequent motion Permanent deformation acceptance Yes
	Yes	Some	No	
<b>High certainty</b> For example, gravity loading and no vibration	0,5	1	2	0,4
<b>Low certainty</b> For example, peak loading	$\geq 1,5$	$\geq 1,5$	$\geq 2$	$\geq 1$

Guideline values for the static safety factor $s_0$ – for continuous and/or occasional loads – roller bearings <sup>1)</sup>				
Certainty of load level	Continuous motion Permanent deformation acceptance			Infrequent motion Permanent deformation acceptance Yes
	Yes	Some	No	
<b>High certainty</b> For example, gravity loading and no vibration	1	1,5	3	0,8
<b>Low certainty</b> For example, peak loading	$\geq 2,5$	$\geq 3$	$\geq 4$	$\geq 2$

1) For spherical roller thrust bearings, use  $s_0 \geq 4$ .

Figs. [SKF 2018]

Fig. [NSK 2011]

Operating Conditions	Lower Limit of $f_s$	
	Ball Bearings	Roller Bearings
Low-noise applications	2	3
Bearings subjected to vibration and shock loads	1.5	2
Standard operating conditions	1	1.5

For spherical thrust roller bearings, the values of  $f_s$  should be greater than 4.

# Bearing selection

## 3. Selection criteria

### 3.2. Bearing size – general information

#### Equivalent bearing loads

##### II. Operation at variable speed and load

##### ii. Load is changing during time

Load may vary periodically over time. In a force-time diagram it may appear as a simple function (e.g., linear or sinusoidal) or as a more complex waveform. In such cases the equivalent dynamic bearing load  $P$  is defined as the mean (constant) load that produces the same fatigue effect as the actual time-varying load. This approach is based on the linear damage hypothesis.

*Load in the form of a linear periodic piecewise function (Fig. 1)*

$$P = \frac{P_{min} + 2P_{max}}{3}$$

*Load in the form similar to sine function (Fig. 2)*

$$(a) \quad P = 0,75P_{max}$$

$$(b) \quad P = 0,65P_{max}$$

*Load in the form of a general periodic function*

$$P = \left[ \frac{1}{t_o} \int_0^{t_o} P(t)^q dt \right]^{1/q}$$

$q = 3$  for ball bearings,  $q = 10/3$  for roller bearings.

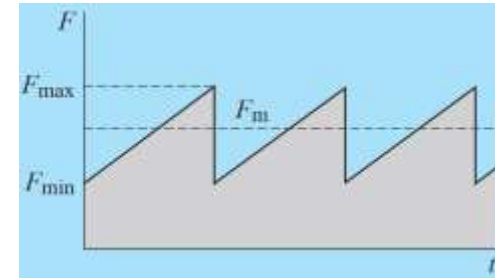

Fig. 1. Linear fluctuating load [NTN 2024]

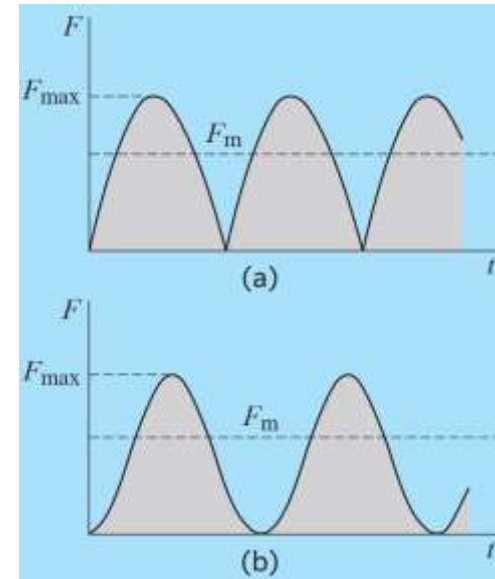

Fig. 2. Sinusoidal fluctuating load [NTN 2024]

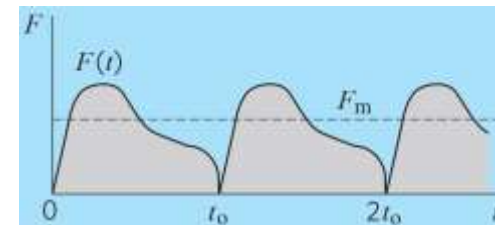

Fig. General regular fluctuating load [NTN 2024]

# Bearing selection

## 3. Selection criteria

### 3.2. Bearing size – general information

#### Equivalent bearing loads

#### II. Operation at variable speed and load

##### iii. Load and speed is changing during time

Load and speed may change gradual over time. In such cases the equivalent dynamic bearing load  $P$  is defined as:

$$P = \left[ \frac{t_1 n_1 P_1^q + t_2 n_2 P_2^q + \dots + t_n n_n P_n^q}{t_1 n_1 + t_2 n_2 + \dots + t_n n_n} \right]^{1/q}$$

where:

$P$  – equivalent dynamic bearing load in N or kN,

$P_n$  – equivalent dynamic bearing load acting during time period  $t_n$  in N or kN,

$t_n$  – time period of machine operation at rotational speed  $n_n$ ,

$n_n$  – rotational speed during which equivalent dynamic bearing load  $P_n$  acts,

$q = 3$  for ball bearings,  $q = 10/3$  for roller bearings.

The mean rotation speed  $n_{mean}$ , required for the determination of bearing life, is given by:

$$n_{mean} = \frac{t_1 n_1 + t_2 n_2 + \dots + t_n n_n}{t_1 + t_2 + \dots + t_n}$$

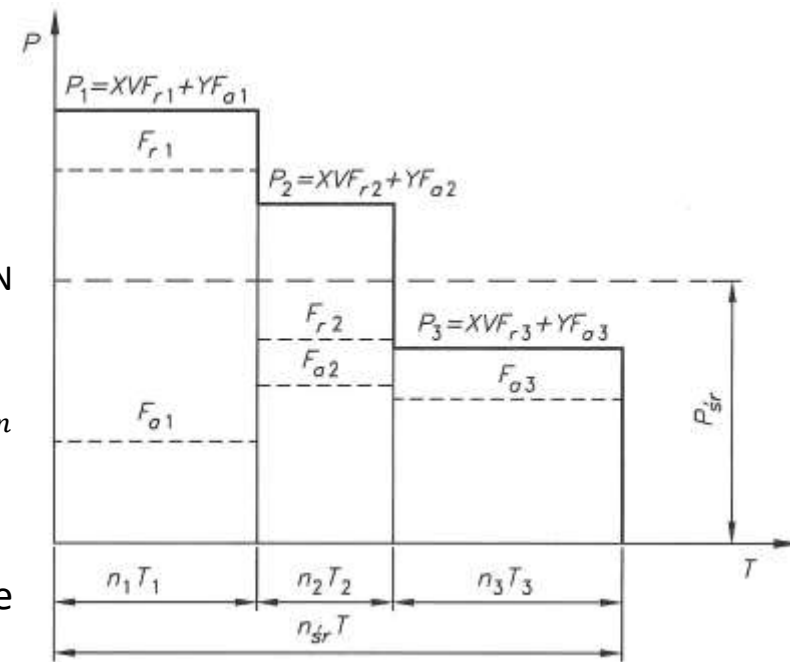

Fig. Gradually changing load [Mazanek 2005]

# Bearing selection

## 3. Selection criteria

### 3.2. Bearing size – general information

#### Equivalent bearing loads

##### II. Operation at variable speed and load

##### iv. Forces with constant and changing direction

Two type of forces may act on a bearing during operation: stationary and rotating. A stationary force has a constant direction and is always present as a result of load transmission or gravity. A rotating force most often results from centrifugal effects due to unbalance. In some types of machines unbalance is a basic principle of operation, while in others it is unavoidable.

According to the Fig. the combine (resultant) load  $F$  based on the law of cosines is:

$$F = \sqrt{R_R^2 + R_S^2 - 2F_R F_S \cos \theta}$$

where:

$F_R$  – rotating force in N,

$F_S$  – stationary force in N,

$\theta$  – angle between forces.

The average load  $F_m$  may be estimated as follows:

when  $F_R \geq F_S$        $F_m = F_R + 0,3F_S + 0,2 \frac{F_S^2}{F_R}$

when  $F_R \leq F_S$        $F_m = F_S + 0,3F_R + 0,2 \frac{F_R^2}{F_S}$

More detailed information can be found in NSK 2011 catalogue.

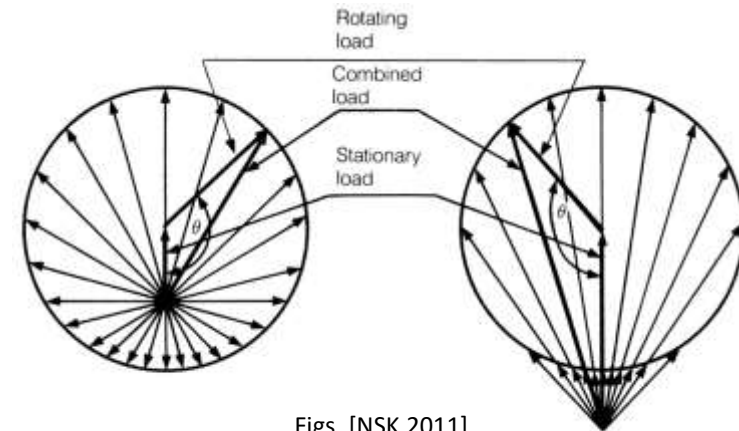
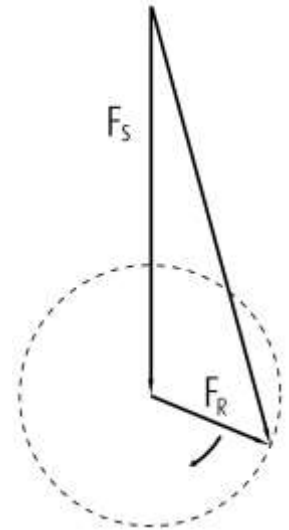

Figs. [NSK 2011]

(a) Rotating load > stationary load

(b) Rotating load < stationary load

# Bearing selection

## 3. Selection criteria

### 3.2. Bearing size – general information

#### Equivalent bearing loads

#### III. Axial load in single row bearings mounted in X and O arrangements

Angular contact and thrust bearings, as well as tapered bearings, must be mounted at least in pairs on a shaft in opposite directions to operate properly. In this type of bearings, even when subjected to purely radial load, an internal axial reaction force is generated. This is due to the bearing's construction and the proportion between radial and axial reaction forces depends on the contact angle.

#### Angular contact ball bearings

This internal axial reaction is taken into account during the estimation of bearings axial load

$K_a$  – external axial force acting on the shaft,

$F_{rA}$  – radial load on bearing A,

$F_{rB}$  – radial load on bearing B,

$F_{aA}$  – resultant axial load on bearing A,

$F_{aB}$  – resultant axial load on bearing B.

Axial loading of bearing arrangements incorporating two single row angular contact ball bearings and/or bearing pairs in tandem

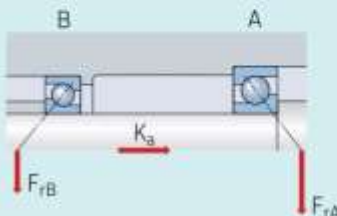
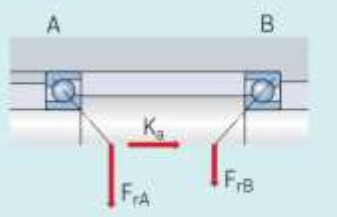
Bearing arrangement	Load case	Axial loads	
	<b>Case 1a</b> $F_{rA} \geq F_{rB}$ $K_a \geq 0$	$F_{aA} = R F_{rA}$	$F_{aB} = F_{aA} + K_a$
	<b>Case 1b</b> $F_{rA} < F_{rB}$ $K_a \geq R(F_{rB} - F_{rA})$	$F_{aA} = R F_{rA}$	$F_{aB} = F_{aA} + K_a$
	<b>Case 1c</b> $F_{rA} < F_{rB}$ $K_a < R(F_{rB} - F_{rA})$	$F_{aA} = F_{aB} - K_a$	$F_{aB} = R F_{rB}$

Contact angle  $\alpha$  - load transmission

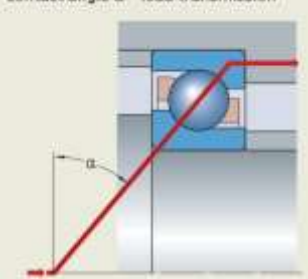

Figs. [SKF 2018]

For bearings with:

- 20° contact angle →  $R = 0,50$
- 25° contact angle →  $R = 0,57$
- 30° contact angle →  $R = 0,66$
- 40° contact angle →  $R = 0,88$

continued ↓

# Bearing selection

## 3. Selection criteria

### 3.2. Bearing size – general information

#### Equivalent bearing loads

#### III. Axial load in single row bearings mounted in X and O arrangements

The presented formulas for determining the resultant axial loads  $F_{aA}$  and  $F_{aB}$  are defined under the following conditions:

- the bearings before loading have neither clearance nor preload and are in the boundary position,
- the radial loads are always taken as positive, regardless of their sense,
- the bearings have the same contact angle.

Angular contact ball bearings

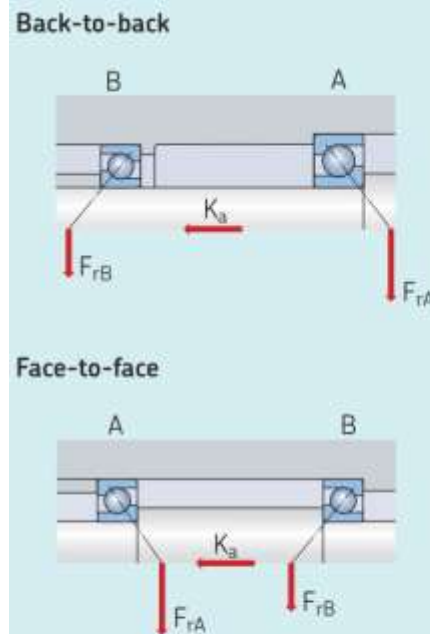

#### Case 2a

$$F_{rA} \leq F_{rB}$$

$$K_a \geq 0$$

$$F_{aA} = F_{aB} + K_a$$

$$F_{aB} = R F_{rB}$$

#### Case 2b

$$F_{rA} > F_{rB}$$

$$K_a \geq R (F_{rA} - F_{rB})$$

$$F_{aA} = F_{aB} + K_a$$

$$F_{aB} = R F_{rB}$$

#### Case 2c

$$F_{rA} > F_{rB}$$

$$K_a < R (F_{rA} - F_{rB})$$

$$F_{aA} = R F_{rA}$$

$$F_{aB} = F_{aA} - K_a$$

$K_a$  – external axial force acting on the shaft,

$F_{rA}$  – radial load on bearing A,

$F_{rB}$  – radial load on bearing B,

$F_{aA}$  – resultant axial load on bearing A,

$F_{aB}$  – resultant axial load on bearing B.

Fig. [SKF 2018]

For bearings with:

- 20° contact angle →  $R = 0,50$
- 25° contact angle →  $R = 0,57$
- 30° contact angle →  $R = 0,66$
- 40° contact angle →  $R = 0,88$

continued ↑

# Bearing selection

## 3. Selection criteria

### 3.2. Bearing size – general information

#### Equivalent bearing loads

#### III. Axial load in single row bearings mounted in X and O arrangements

Tapered roller bearings

Axial loading of bearing applications incorporating two single row tapered roller bearing arrangements and/or bearing pairs in tandem

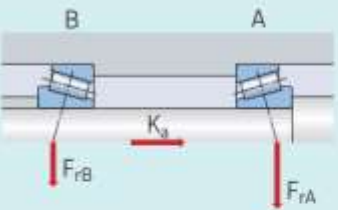
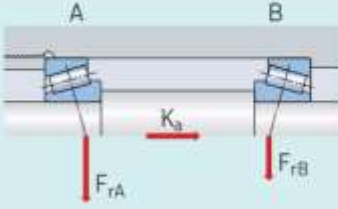
Bearing arrangement	Load case	Axial loads	
<b>Back-to-back</b> 	<b>Case 1a</b> $\frac{F_{rA}}{Y_A} \geq \frac{F_{rB}}{Y_B}$ $K_a \geq 0$	$F_{aA} = \frac{0,5 F_{rA}}{Y_A}$	$F_{aB} = F_{aA} + K_a$
<b>Face-to-face</b> 	<b>Case 1b</b> $\frac{F_{rA}}{Y_A} < \frac{F_{rB}}{Y_B}$ $K_a \geq 0,5 \left( \frac{F_{rB}}{Y_B} - \frac{F_{rA}}{Y_A} \right)$	$F_{aA} = \frac{0,5 F_{rA}}{Y_A}$	$F_{aB} = F_{aA} + K_a$
	<b>Case 1c</b> $\frac{F_{rA}}{Y_A} < \frac{F_{rB}}{Y_B}$ $K_a < 0,5 \left( \frac{F_{rB}}{Y_B} - \frac{F_{rA}}{Y_A} \right)$	$F_{aA} = F_{aB} - K_a$	$F_{aB} = \frac{0,5 F_{rB}}{Y_B}$

Figs. [SKF 2018]

$K_a$  is the external axial force acting on the shaft or on the housing. Load cases 1c and 2c are also valid when  $K_a = 0$ .

Values of the calculation factor Y are listed in the product tables.

continued ↓

# Bearing selection

## 3. Selection criteria

### 3.2. Bearing size – general information

#### Equivalent bearing loads

#### III. Axial load in single row bearings mounted in X and O arrangements

#### Tapered roller bearings

$K_a$  – external axial force acting on the shaft,

$F_{rA}$  – radial load on bearing A,

$F_{rB}$  – radial load on bearing B,

$F_{aA}$  – resultant axial load on bearing A,

$F_{aB}$  – resultant axial load on bearing B

$Y_A$  – axial load factor for bearing A (from table).

$Y_B$  – axial load factor for bearing B (from table).

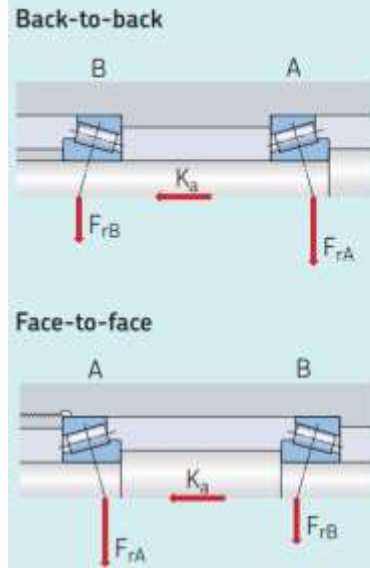

Figs. [SKF 2018]

$K_a$  is the external axial force acting on the shaft or on the housing. Load cases 1c and 2c are also valid when  $K_a = 0$ .

Values of the calculation factor Y are listed in the product tables.

#### Case 2a

$$\frac{F_{rA}}{Y_A} \leq \frac{F_{rB}}{Y_B}$$

$$K_a \geq 0$$

$$F_{aA} = F_{aB} + K_a$$

$$F_{aB} = \frac{0,5 F_{rB}}{Y_B}$$

#### Case 2b

$$\frac{F_{rA}}{Y_A} > \frac{F_{rB}}{Y_B}$$

$$K_a \geq 0,5 \left( \frac{F_{rA}}{Y_A} - \frac{F_{rB}}{Y_B} \right)$$

$$F_{aA} = F_{aB} + K_a$$

$$F_{aB} = \frac{0,5 F_{rB}}{Y_B}$$

#### Case 2c

$$\frac{F_{rA}}{Y_A} > \frac{F_{rB}}{Y_B}$$

$$K_a < 0,5 \left( \frac{F_{rA}}{Y_A} - \frac{F_{rB}}{Y_B} \right)$$

$$F_{aA} = \frac{0,5 F_{rA}}{Y_A}$$

$$F_{aB} = F_{aA} - K_a$$

continued ↑

# Bearing selection

## 3. Selection criteria

### 3.2. Bearing size – general information

#### Minimum load

Rolling bearings require a minimum load to ensure that the rolling elements rotate rather than slide. If the load is too small, slippage may occur and the bearing may fail prematurely due to skidding and smearing. This situation may arise when the shaft dimensions determine the bearing size (for example, when a large shaft diameter is required due to critical speed considerations) or when a very long bearing life has been assumed in the design.

Possible solutions include:

- using a smaller bearing within the bearing series.
- applying preload,
- reducing bearing friction by selecting a special low-friction bearing design (available from some manufacturers) or by using a special lubrication system.

The importance of maintaining the minimum load increases when rotational accelerations are high. General guidance for minimum load is as follows:

- ball bearings  $P = \frac{C_0}{100}$ ,
- roller bearings  $P = \frac{C_0}{60}$ .

More precise values are provided in manufacturers' bearing catalogues.

Fig. [FAG 2025]

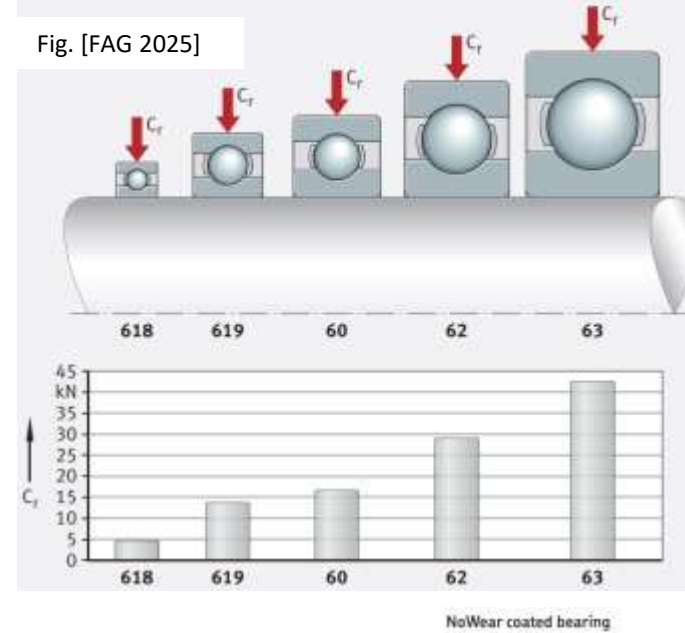

Figs. [SKF 2018]

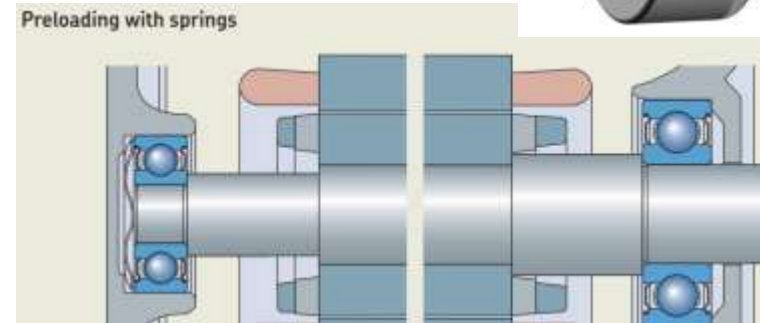

# Bearing selection

## 3. Selection criteria

### 3.2. Bearing size – basic rating life $L$

The experimental data, according to Palmgren, are presented in the figure. The x-axis shows the bearing life  $L$  and the y-axis shows the force  $F$  applied to the bearing. A clear trend is visible in this plot: as the force decreases, the rated life increases. The data are approximated by the function developed by Palmgren [Palmgren 1951]:

$$F L^{1/q} = \text{constant}$$

Because of logarithmic scale of the axes, the approximation looks like a line.

The power  $q$  has value that depends on the bearing type, based on the test adopted:

$q = 3$  for ball bearings,

$q = 10/3$  for roller bearings.

The dependency between bearing load and bearing life is expected. The higher the load the lower the bearing life but the relationship is not linear. Doubling the force will cause a several times shorter life.

Information that product of force  $F$  and life  $L^{1/q}$  is constant for any logically limited values is important.

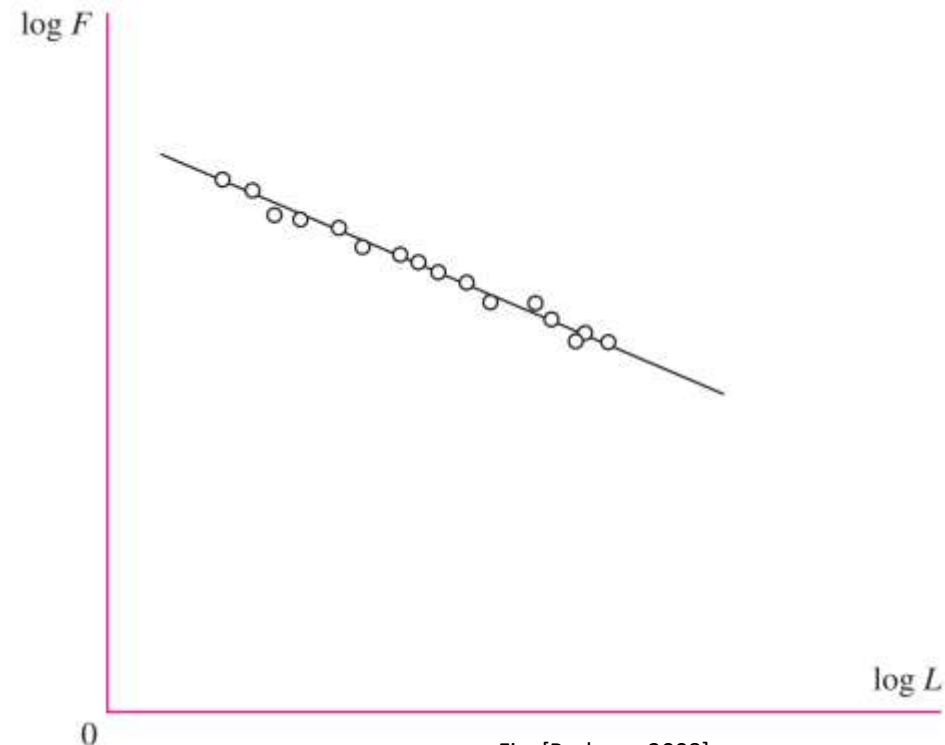

Fig. [Budynas 2008]

# Bearing selection

## 3. Selection criteria

### 3.2. Bearing size – basic rating life $L$

Therefore, it can be written:

$$F_R L_R^{1/q} = F_D L_D^{1/q} = \text{constant}$$

where the subscript  $R$  means rated (known or measured) and  $D$  means desired (required). After reordering:

$$\frac{L_D}{L_R} = \left( \frac{F_R}{F_D} \right)^q$$

Recalling the previous information on bearing life  $L$  and the dynamic load rating  $C$ , as given in manufacturers' catalogues where tests are conducted at a 10% probability of bearing failure (90% reliability), it may be stated that:

$$F_R = C \text{ [N]},$$

$$L_R = 1 \text{ million revolutions,}$$

and the pure radial or axial force is replaced by the equivalent bearing load:

$$F_D = P \text{ [N]}.$$

Thus:

$$\frac{L_D}{L_R} = \left( \frac{C}{P} \right)^q$$

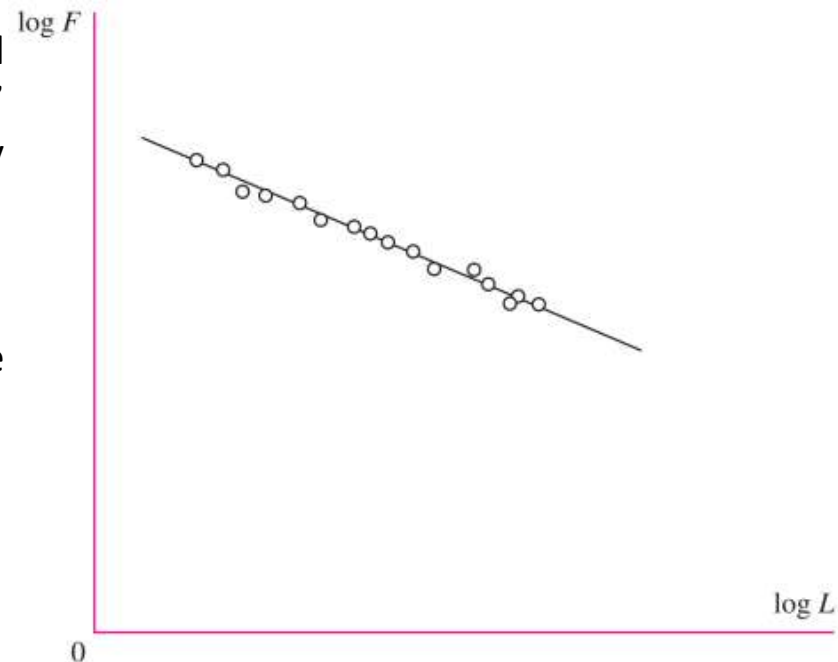

Fig. [Budynas 2008]

# Bearing selection

## 3. Selection criteria

### 3.2. Bearing size – basic rating life $L$

The life of a bearing is usually required to be expressed in terms of the number of operating hours. Units based on the number of revolutions can be converted according to the following equation:

$$L_h = \frac{L_R}{60 n}$$

where:

$L_h$  – bearing life in hours,

$L_R = 10^6$  rated bearing life expressed in revolutions (typically  $10^6$  revolutions, as defined by test conditions, although other values may be used, e.g.  $L_R = 9 \times 10^7$ ),

$n$  – actual or average rotational speed, in revolutions per minute.

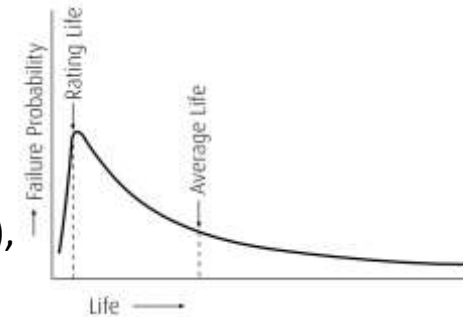

Fig. [NSK 2011]

Typically, two problems are considered:

– when the bearing has been selected and the bearing life in hours must be determined from the equivalent dynamic bearing load and the dynamic load rating:

$$L_{Dh} = \frac{L_R}{60 n} \left( \frac{C}{P} \right)^q$$

– Determination of the minimum dynamic load rating, when the equivalent dynamic bearing load and the required bearing life are known:

$$C = P \left( \frac{L_D}{L_R} \right)^{1/q} = P \left( \frac{60 n L_{Dh}}{L_R} \right)^{1/q}$$

# Bearing selection

## 3. Selection criteria

### 3.2. Bearing size – basic rating life $L$

The relationship between bearing life and load is often expressed in a different form from that given previously:

$$\frac{L_D}{L_R} = \left(\frac{C}{P}\right)^q$$

If the rated life is assumed to be  $10^6$  revolutions and signed up  $L_R = 1$  million revolutions,  $L_D$  denoted as  $L$  the equation may be written as:

$$L = \left(\frac{C}{P}\right)^q \text{ millions of revolutions}$$

and

$$L_h = \frac{10^6}{60 n} \left(\frac{C}{P}\right)^q$$

$$C = P \left(\frac{L}{10^6}\right)^{1/q} = P \left(\frac{60 n L_h}{10^6}\right)^{1/q}$$

where:

$L$  or  $L_{10}$  – basic rating life corresponding to a 10% probability of bearing failure (90% reliability). Fig. [SKF 2018]

Unit conversion factors for bearing life



Basic units	Conversion factor Million revolutions	Operating hours	Million kilometres	Million oscillation cycles <sup>1)</sup>
1 million revolutions	1	$\frac{10^6}{60 n}$	$\frac{n D}{10^3}$	$\frac{180}{2 \gamma}$
1 operating hour	$\frac{60 n}{10^6}$	1	$\frac{60 n n D}{10^3}$	$\frac{180 \times 60 n}{2 \gamma \cdot 10^6}$
1 million kilometres	$\frac{10^3}{n D}$	$\frac{10^6}{60 n n D}$	1	$\frac{180 \times 10^3}{2 \gamma n D}$
1 million oscillation cycles <sup>1)</sup>	$\frac{2 \gamma}{180}$	$\frac{2 \gamma \cdot 10^6}{180 \times 60 n}$	$\frac{2 \gamma n D}{180 \times 10^3}$	1

$D$  = vehicle wheel diameter [m]  
 $n$  = rotational speed [r/min]  
 $\gamma$  = oscillation amplitude (angle of max. deviation from centre position) [°]

# Bearing selection

## 3. Selection criteria

### 3.2. Bearing size – basic rating life $L$

Guideline for assessment of bearing life in hours and kilometres

Service classification	Machine application and requisite life $L_{10h}$ ×10 <sup>3</sup> hours				
	Up to 4	4 to 12	12 to 30	30 to 60	60 or more
Machines used for short periods or used only occasionally	Household appliances Electric hand tools	Farm machinery Office equipment			
Short period or intermittent use, but with high reliability requirements	Medical appliances Measuring instruments	Home air-conditioning motor Construction equipment Elevators Cranes	Crane (sheaves)		
Machines not in constant use, but used for long periods	Automobiles Two-wheeled vehicles	Small motors Buses/trucks General gear drives Woodworking machines	Machine spindles Industrial motors Crushers Vibrating screens	Main gear drives Rubber/plastic Calender rolls Printing machines	
Machines in constant use over 8 hours a day		Roll neck of steel mill Escalators Conveyors Centrifuges	Railway vehicle axles Air conditioners Large motors Compressor pumps	Locomotive axles Traction motors Mine hoists Pressed flywheels	Papermaking machines Propulsion equipment for marine vessels
24 hour continuous operation, non-interruptible					Water supply equipment Mine drain pumps/ventilators Power generating equipment

Fig. [NTN 2024]

15  
Gearboxes in general machine building

Mounting location	Recommended rating life h				Operating life h	
	Ball bearings		Roller bearings		from to	
	from	to	from	to		
Universal gearboxes	4 000	14 000	5 000	20 000	5 000	20 000
Geared motors	4 000	14 000	5 000	20 000	5 000	20 000
Large gearboxes, stationary	14 000	46 000	20 000	75 000	20 000	80 000

Figs. [FAG 2025]

13  
Machine tools

Mounting location	Recommended rating life h				Operating life h	
	Ball bearings		Roller bearings		from to	
	from	to	from	to		
Headstock spindles, milling spindles	14 000	46 000	20 000	75 000	10 000	30 000
Drilling spindles	14 000	32 000	20 000	50 000	1 000	20 000
External grinding spindles	7 800	21 000	10 000	35 000	10 000	20 000
Hole grinding spindles	–				500	2 000
Workpiece spindles in grinding machines	21 000	63 000	35 000	110 000	20 000	30 000
Machine tool gearboxes	14 000	32 000	20 000	50 000	10 000	20 000
Presses, flywheels	21 000	32 000	35 000	50 000	20 000	30 000
Presses, eccentric shafts	14 000	21 000	20 000	35 000	10 000	20 000
Electric tools and compressed air tools	4 000	14 000	5 000	20 000	100	200

6  
Motor vehicles

Mounting location	Recommended rating life h			
	Ball bearings		Roller bearings	
	from	to	from	to
Motorcycles	400	2 000	400	2 400
Passenger car powertrains	500	1 100	500	1 200
Passenger car gearboxes protected against contamination	200	500	200	500
Passenger car wheel bearings	1 400	5 300	1 500	7 000
Light commercial vehicles	2 000	4 000	2 400	5 000
Medium commercial vehicles	2 900	5 300	3 600	7 000
Heavy commercial vehicles	4 000	8 800	5 000	12 000
Buses	2 900	11 000	3 600	16 000
Internal combustion engines	900	4 000	900	5 000

7  
Rail vehicles

Mounting location	Operating life Millions of kilometres	
	from	to
Wheelset bearings for freight wagons	0,1	0,1
Urban transport vehicles	1	2
Passenger carriages	2	3
Goods wagons	1	2
Tipper wagons	1	2
Powered units	2	3
Locomotives, external bearings	2	4
Locomotives, internal bearings	2	4
Shunting and industrial locomotives	0,5	1
Gearboxes for rail vehicles	0,5	2

# Bearing selection

## 3. Selection criteria

### 3.2. Bearing size – modified rating life $L_{na}$

The basic rating life  $L$  (or  $L_{10}$ ) is defined for a 10% probability of bearing failure (90% reliability), standard quality bearings, adequate lubrication and other conditions considered favourable.

In practical applications, operating conditions may significantly differ from those assumed during testing. To adopt basic rating life  $L_{10}$  to such conditions appropriate life adjustment factors are applied. The resulting value is referred to as the modified rating life, denoted as  $L_{na}$  (also written as  $L_{nm}$  or  $L_e$ ):

$$L_{na} = a_1 a_2 a_3 L_{10} = a_1 a_{ISO} L_{10}$$

where:

$a_1$  – life adjustment factor for reliability,

$a_2$  – life adjustment factor for special bearing properties,

$a_3$  – life adjustment factor for operating conditions,

$L_{10}$  – basic rating life corresponding to a 10% probability of bearing failure (90% reliability),

$a_{ISO} = a_2 a_3$  – life modification factor according to ISO.

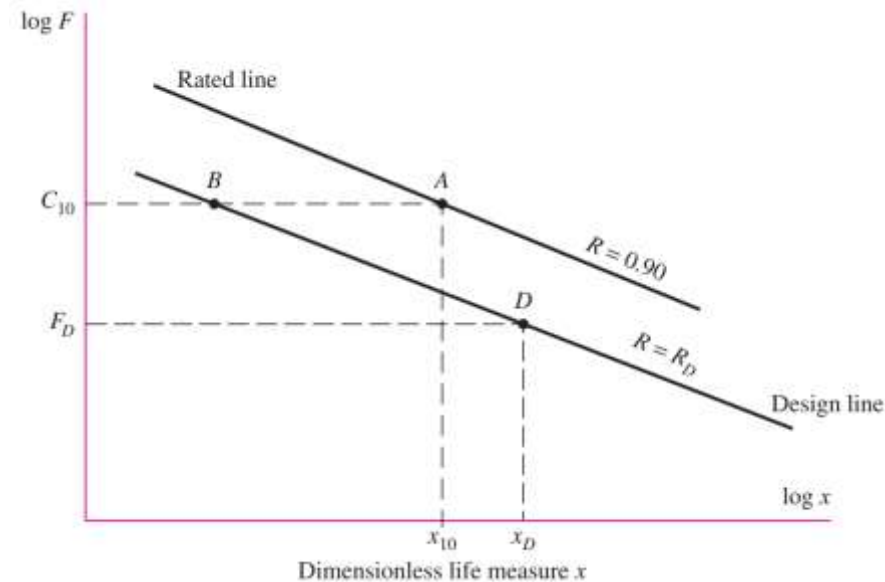

Fig. [Budynas 2008]

# Bearing selection

## 3. Selection criteria

### 3.2. Bearing size – modified rating life $L_{na}$

#### **The life adjustment factor for reliability $a_1$**

A reliability level of 90% is most often considered the minimum acceptable value in engineering applications. For more demanding applications, such as those in the aviation industry, higher reliability levels are required. The table presents reliability levels and the corresponding values of the life adjustment factor for reliability  $a_1$ .

#### **The life adjustment factor for special bearing properties $a_2$**

For standards bearings  $a_2 = 1$ . For bearings with improved properties resulting from enhanced materials and manufacturing processes  $a_2 > 1$ . If a bearing operates at elevated temperatures  $a_2 \leq 1$ . The table presents values of the factor  $a_2$  for bearings with temperature stabilisation treatment (TS) and the corresponding maximum operating temperatures, according to the NTN catalogue.

#### **The life adjustment factor for operating conditions $a_3$**

For adequate lubrication conditions  $a_3 = 1$ . Lubrication conditions may be considered severe due to the following factors [NTN, 2024]:

- insufficient dynamic viscosity,
- to low rotational speed,
- lubricant contamination.

Under such conditions  $a_3 < 1$ .

Reliability %	$L_n$	Life adjustment factor for reliability $a_1$
90	$L_{10}$	1.00
95	$L_5$	0.64
96	$L_4$	0.55
97	$L_3$	0.47
98	$L_2$	0.37
99	$L_1$	0.25
99.2	$L_{0.8}$	0.22
99.4	$L_{0.6}$	0.19
99.6	$L_{0.4}$	0.16
99.8	$L_{0.2}$	0.12
99.9	$L_{0.1}$	0.093
99.92	$L_{0.08}$	0.087
99.94	$L_{0.06}$	0.080
99.95	$L_{0.05}$	0.077

Fig. [NTN 2024]

Code	Max. operating temperature °C	Life adjustment factor for special bearing properties $a_2$
TS2	160	1.00
TS3	200	0.73
TS4	250	0.48

Fig. [NTN 2024]

# Bearing selection

## 3. Selection criteria

### 3.2. Bearing size – modified rating life $L_{na}$

#### The life modification factor $a_{ISO}$

Previously the factors  $a_2$  and  $a_3$  were considered separately. In the ISO 281:2007 standard these two factors are combined into a single factor. This approach is more practical, as the factors are not independent; for example, increased temperature affects both the bearing material properties and the lubricant performance.

Assessment of life modification factor  $a_{ISO}$  requires four parameters:

$$a_{ISO} = f\left(\frac{e_c C_u}{P}, \kappa\right)$$

where:

$P$  – equivalent dynamic bearing load [N]

$C_u$  – fatigue load limit, value from manufacturer's catalogue [N]

$e_c$  – contamination factor from the Table 3.4.  $D_{pw}$  – rolling element pitch diameter [mm],

$\kappa$  – viscosity ratio.

The viscosity ratio is defined as:

$$\kappa = v/v_1$$

where:

$v$  – dynamic (rather kinematic) viscosity [mm<sup>2</sup>/s or m<sup>2</sup>/s ],

$v_1$  – reference dynamic viscosity [mm<sup>2</sup>/s or m<sup>2</sup>/s ].

Table 3.4 Value of contamination factor  $e_c$

Level of contamination	$e_c$	
	$D_{pw} < 100 \text{ mm}$	$D_{pw} \geq 100 \text{ mm}$
<b>Extreme cleanliness</b> Particle size of the order of lubricant film thickness; laboratory conditions	1	1
<b>High cleanliness</b> Oil filtered through extremely fine filter; conditions typical of bearing greased for life and sealed	0.8–0.6	0.9–0.8
<b>Normal cleanliness</b> Oil filtered through fine filter; conditions typical of bearings greased for life and shielded	0.6–0.5	0.8–0.6
<b>Slight contamination</b> Slight contamination in lubricant	0.5–0.3	0.6–0.4
<b>Typical contamination</b> Conditions typical of bearings without integral seals; coarse filtering; wear particles and ingress from surroundings	0.3–0.1	0.4–0.2
<b>Severe contamination</b> Bearing environment heavily contaminated and bearing arrangement with inadequate sealing	0.1–0	0.1–0
<b>Very severe contamination</b>	0	0

# Bearing selection

## 3. Selection criteria

### 3.2. Bearing size – modified rating life $L_{na}$

#### The life modification factor $a_{ISO}$

There are minimum requirements for dynamic viscosity as given in Table 11.8. From Figure 11.5 dynamic viscosity can be assessed. Finally, the reference dynamic viscosity value may be read from Diagram 3.2.

Table 11.8 Required lubricating oil viscosity for bearings

Bearing type	Dynamic viscosity $\text{mm}^2/\text{s}$
Ball bearings, Cylindrical roller bearings, Needle roller bearings	13 or above
Spherical roller bearings, Tapered roller bearings, Thrust needle roller bearings	20 or above
Thrust spherical roller bearings	30 or above

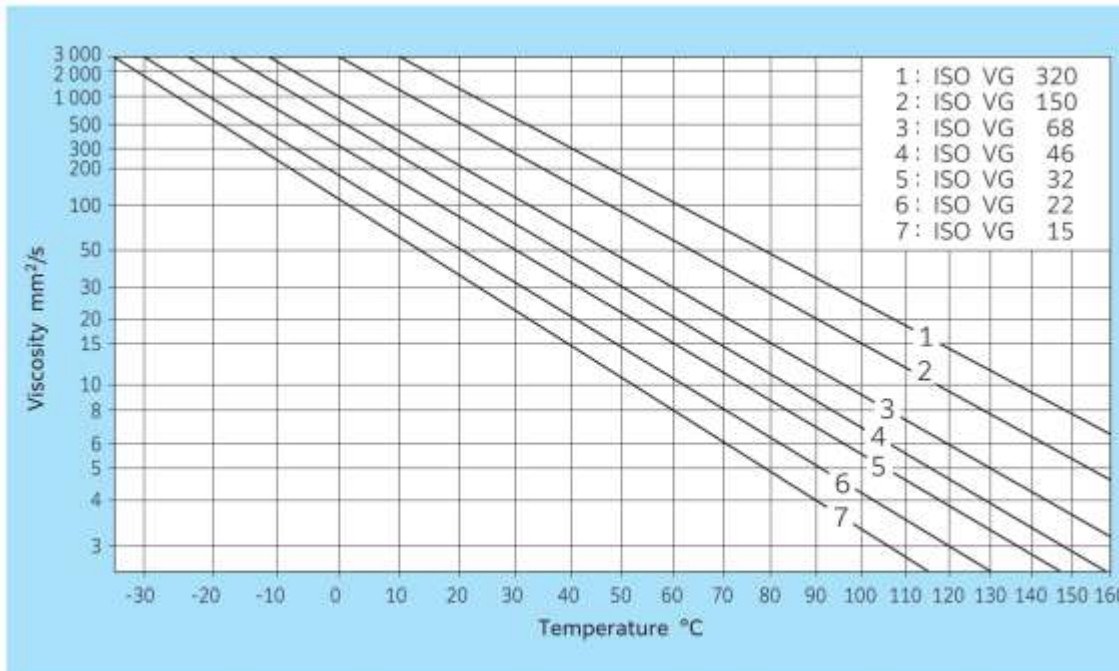

Fig 11.5 Relation between lubricating oil viscosity and temperature

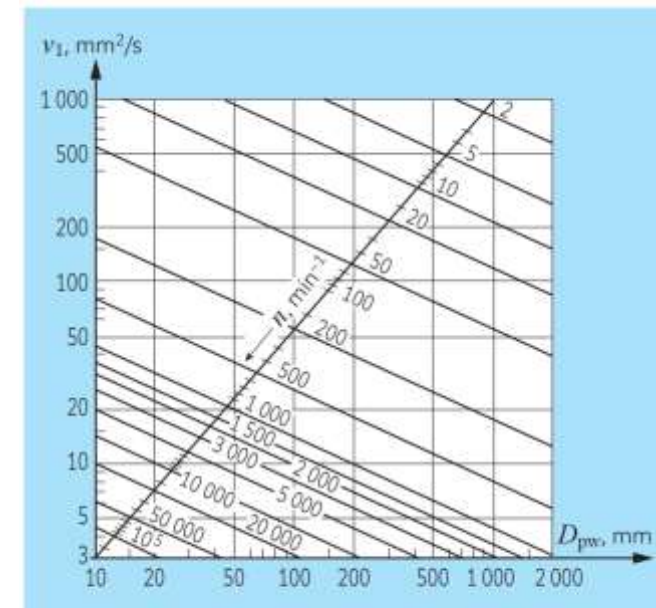

Fig. 3.2 Diagram for reference dynamic viscosity  $v_1$

# Bearing selection

## 3. Selection criteria

### 3.2. Bearing size – modified rating life $L_{na}$

The life modification factor  $a_{ISO}$

Once all required data are available, the parameter

$$\frac{e_c C_u}{P}$$

can be calculated and the life modification factor  $a_{ISO}$  determined.

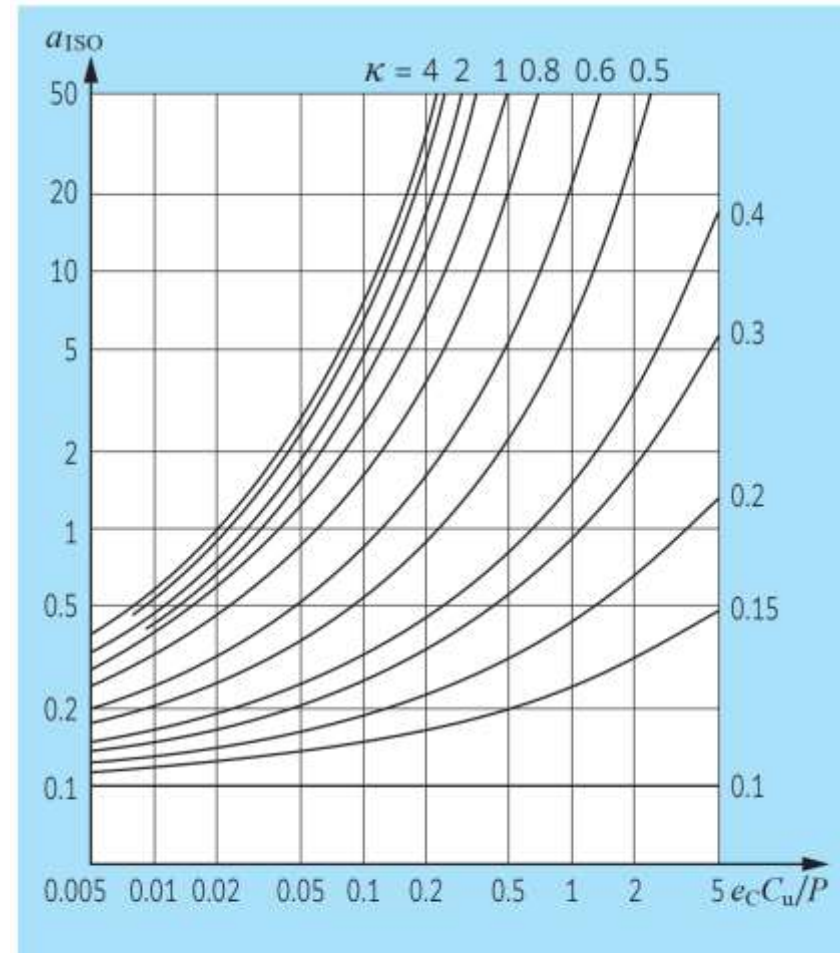

Fig. 3.3 Life modification factor  $a_{ISO}$  (radial ball bearing)

# Bearing selection

## 3. Selection criteria

### 3.2. Bearing size – remarks on bearing life

In addition to the introduction to bearing life, two further aspects should be considered: the reliability of a group of bearings and bearing failure modes.

#### *Group of bearings*

The reliability of a single bearing does not represent the reliability of several bearings operating within a machine or a complete unit. As the number of bearings increases, the likelihood of failure within the bearing system increases. The overall bearing life of a group can be assessed using the following equation [NTN 2024] :

$$L = \frac{1}{\left(\frac{1}{L_1^e} + \frac{1}{L_2^e} + \dots + \frac{1}{L_n^e}\right)^{1/e}}$$

where:

$L$  – total basic rating life of the entire group of bearings,

$L_n$  – basic rating life of  $n$ th individual bearing,

$e$ :  $e = 10/9$  – exponent for ball bearings.

$e = 9/8$  – exponent for roller bearings.

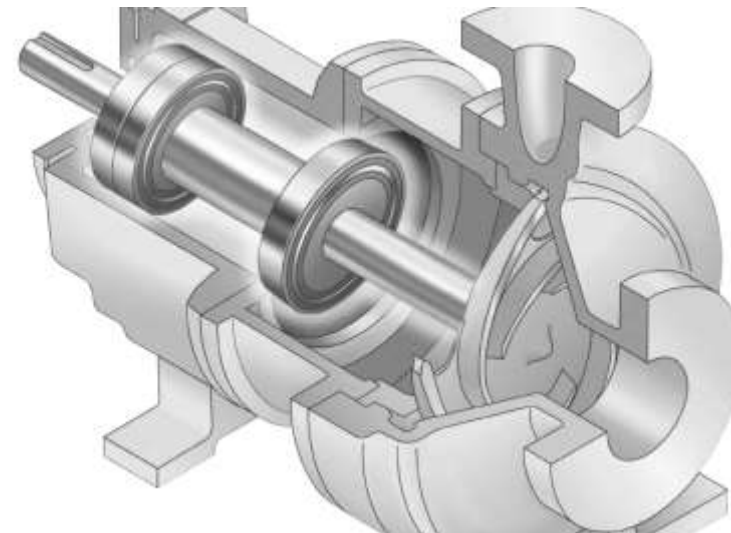

Fig. [NSK 2011]

# Bearing selection

## 3. Selection criteria

### 3.2. Bearing size – remarks on bearing life

#### Bearing failures modes

The basic and modified rating life are established for very good operating conditions from the bearing perspective. Under such conditions bearing naturally wear in the form of fatigue failure manifested as spalling (flaking). Other types of bearing failure also exist; however, they are most often considered to result from errors in bearing selection, handling, lubrication or manufacturing. This means that such failure modes should be avoided through proper design, installation and production.

<p><b>Spalling (Flaking)</b></p>  <p> <ul style="list-style-type: none"> <li>● Inner ring of spherical roller bearing</li> <li>● Spalling on one row of the raceway surface in this case.</li> <li>● An excessive axial load is the cause.</li> </ul> </p>	<p>The surface of the raceway and rolling elements peel away in flakes leaving a highly irregular and very poor surface.</p>  <p> <ul style="list-style-type: none"> <li>● Outer ring of angular contact ball bearing</li> <li>● Spalling on the raceway surface with spacing equal to the distance between balls.</li> <li>● Improper handling is the cause.</li> </ul> </p>	<p><b>Causes</b></p> <ul style="list-style-type: none"> <li>● Excessive load, normal fatigue life, improper handling</li> <li>● Improper installation</li> <li>● Insufficient accuracy of shaft or housing</li> <li>● Insufficient clearance</li> <li>● Contamination</li> <li>● Rust</li> <li>● Insufficient lubrication</li> <li>● Reduction in hardness due to abnormal temperature rise</li> </ul> <p><b>Correction</b></p> <ul style="list-style-type: none"> <li>● Select a different type or size of bearing.</li> <li>● Reevaluate the clearance.</li> <li>● Improve the precision of the shaft and housing.</li> <li>● Improve assembly method and handling.</li> <li>● Reevaluate the layout (design) of the area around the bearing.</li> <li>● Review lubricant type and lubrication methods.</li> </ul>
<p><b>Seizure</b></p>  <p> <ul style="list-style-type: none"> <li>● Inner ring of double-row tapered roller bearing</li> <li>● Seizure causes discoloration and softening, producing stepped abrasion on the raceway surface with spacing equal to the distance between the rollers.</li> <li>● Insufficient lubrication is the cause.</li> </ul> </p>	<p>Extreme thermal conditions eventually resulting in seizure of the bearing.</p>  <p> <ul style="list-style-type: none"> <li>● Inner ring of tapered roller bearing</li> <li>● Evidence of seizure on the large diameter side of raceway surface and large rib surface</li> <li>● Insufficient lubrication is one possible cause.</li> </ul> </p>	<p><b>Causes</b></p> <ul style="list-style-type: none"> <li>● Insufficient clearance (including clearances reduced by local deformation)</li> <li>● Insufficient lubrication or improper lubricant</li> <li>● Excessive loads (including excessive preload)</li> <li>● Roller skewing due to a misaligned bearing</li> <li>● Reduction in hardness due to abnormal temperature rise</li> <li>● High speed or large fluctuating load</li> </ul> <p><b>Correction</b></p> <ul style="list-style-type: none"> <li>● Review lubricant type and quantity.</li> <li>● Check for proper clearance. (Increase clearances.)</li> <li>● Take steps to prevent misalignment.</li> <li>● Improve assembly method and handling.</li> </ul>
<p><b>Cracks/chips</b></p>  <p> <ul style="list-style-type: none"> <li>● Inner ring of tapered roller bearing</li> <li>● Chipped large rib.</li> <li>● Impact due to improper preloading is the cause.</li> </ul> </p>	<p>Localized spalling occurs. Little cracks or notches appear.</p>  <p> <ul style="list-style-type: none"> <li>● Outer ring of four-row cylindrical roller bearing</li> <li>● Cracks in the circumferential direction of raceway surface</li> <li>● These cracks were initiated by spalling.</li> </ul> </p>	<p><b>Causes</b></p> <ul style="list-style-type: none"> <li>● Excessive shock loads</li> <li>● Improper handling (use of steel hammer, damage from large particle contamination)</li> <li>● Formation of decomposed surface layer due to improper lubrication</li> <li>● Excessive interference</li> <li>● Spalling</li> <li>● Friction cracking</li> <li>● Imprecise mating component (oversized fillet radius)</li> </ul> <p><b>Correction</b></p> <ul style="list-style-type: none"> <li>● Review lubricant (friction crack prevention).</li> <li>● Select proper interference and review materials.</li> <li>● Improve assembly method and handling.</li> </ul>

Fig. [NTN 2024]

# Bearing selection - bearing failures modes

**Rust/ corrosion** The surface becomes either partially or fully rusted, and occasionally rust occurs spaced at equal distances between rolling elements.



- Inner ring of tapered roller bearing
- Rust at equal distances between rolling elements on raceway surface.



- Outer ring of deep groove ball bearing
- Rust on the outside diameter surface.

- Causes**
- Poor storage conditions
  - Poor packaging
  - Insufficient rust inhibitor
  - Penetration by water, acid, etc.
  - Handling with bare hands

- Correction**
- Take measures to prevent rusting while in storage.
  - Periodically inspect the lubricating oil.
  - Improve sealing performance.
  - Improve assembly method and handling.

**Fretting** There are two types of fretting. In one, a rusty wear powder forms on the mating surfaces. In the other, brinelling indentations form on the raceway corresponding to rolling element spacing.



- Inner ring of cylindrical roller bearing
- Ripple-like fretting on the entire circumference of the raceway surface.
- Vibration is the cause.



- Inner ring of deep groove ball bearing
- Fretting on the entire circumference of the raceway surface.
- Vibration is the cause.

- Causes**
- Insufficient interference
  - Small bearing oscillation angle
  - Insufficient lubrication
  - Fluctuating loads
  - Vibration during transport, or while stopped

- Correction**
- Review lubricant type and lubrication methods.
  - Review the interference fit and apply a coat of lubricant to fitting surface.
  - Pack the inner and outer rings separately for transport.

**Wear** The surfaces wear and dimensional deformation results. Wear is often accompanied by roughness and scratches.



- Inner ring of cylindrical roller bearing
- Stepped wear on the entire circumference of the raceway surface.
- Insufficient lubrication is the cause.



- Cage of cylindrical roller bearing
- Wear of pocket part of high strength, machined brass cage

- Causes**
- Entrapment of foreign particles in the lubricant
  - Inadequate lubrication
  - Roller skewing due to a misaligned bearing

- Correction**
- Review lubricant type and lubrication methods.
  - Improve sealing performance.
  - Take steps to prevent misalignment.
  - Improve assembly method and handling.

**Electrolytic corrosion** Pits form on the raceway. The pits gradually grow into ripples.



- Inner ring of deep groove ball bearing
- Ripple-like electrolytic corrosion on the raceway surface.



- The cross section of the electrolytic corrosion on the roller rolling element surface is enlarged (x400).
- The white layer shows up by nital etching of the cross section.

- Causes**
- Electric current flowing through the rollers

- Correction**
- Create a bypass circuit for the current.
  - Insulate the bearing.

**Cage damage** Rivets break or become loose resulting in cage damage. Fracture of riveted steel cage at the corner radius.



- Cage of angular contact ball bearing
- Breakage of high strength, machined brass cage
- Insufficient lubrication is the cause.



- Cage of cylindrical roller bearing
- Breakage of partitions between pockets of high strength, machined brass cage

- Causes**
- Excessive load or moment loading
  - High speed or excessive speed fluctuations
  - Insufficient lubrication
  - Impact with foreign objects
  - Excessive vibration
  - Improper mounting (mounted misaligned)



- Cage of deep groove ball bearing
- Breakage of riveted steel cage



- Cage of deep groove ball bearing
- Breakage at corner of riveted steel cage

- Correction**
- Review lubricant type and lubrication methods.
  - Review cage type selection.
  - Investigate shaft and housing rigidity.
  - Improve assembly method and handling.

**Rolling path skewing** Abrasion or an irregular, rolling path skewing due to rolling elements along raceway surfaces.



- Spherical roller bearing
- Uneven contact on inner ring, outer ring, and roller
- Improper installation is the cause.



- Roller of tapered roller bearing
- Evidence of uneven contact on rolling element surface

- Causes**
- Insufficient accuracy of shaft or housing
  - Improper installation
  - Insufficient shaft or housing rigidity
  - Shaft whirling caused by excessive internal bearing clearances

- Correction**
- Reevaluate the clearance.
  - Improve the precision of the shaft and housing.
  - Review rigidity of shaft and housing.

**Smearing, Scuffing** The surface becomes rough and some small deposits form. Scuffing generally refers to roughness on the race rib face and the ends of the rollers.



- Inner ring of cylindrical roller bearing
- Scuffing on the rib surface.



- Inner ring of cylindrical roller bearing
- Smearing on the raceway surface.
- The cause is slippage of rollers due to contaminants.

- Causes**
- Insufficient lubrication
  - Contamination ingress
  - Roller skewing due to a misaligned bearing
  - Bare spots in the collar oil film due to large axial loading
  - Excessive slippage of the rolling elements

- Correction**
- Review lubricant type and lubrication methods.
  - Improve sealing performance.
  - Improve preload.
  - Improve assembly method and handling.

# Bearing selection - bearing failures modes

**Scratching and Denting** Scoring during assembly, gouges due to hard foreign objects, and surface denting due to mechanical shock.

- Roller of cylindrical roller bearing
- Axial direction scratches on the rolling element surface at the time of preloading
- Improper preloading is the cause.
- Inner ring of tapered roller bearing
- Dents on the entire raceway surface
- Impact with hard foreign objects is the cause.

- Causes**
- Entrapment of hard foreign matter
  - Dropping or other mechanical shocks due to careless handling
  - Assembled misaligned
  - Excessive load or moment loading
- Correction**
- Improve assembly method and handling.
  - Improve sealing performance (to prevent infiltration of foreign matter).
  - Check area surrounding bearing (when caused by metal fragments).

**Creeping** Surface becomes mirrored due to bore and outside diameter bearing surfaces spinning against the mating shaft or housing surface during operation. May be accompanied by discoloration or scoring.

- Inner ring of deep groove ball bearing
- Mirrored bore surface due to creeping on the shaft.
- Inner ring of tapered roller bearing
- Scuffing on bore surface due to creeping on the shaft.

- Causes**
- Insufficient interference with mating component
  - Sleeve not fastened down properly
  - Abnormal temperature rise
  - Excessive loads
  - High speed/rapid acceleration or deceleration
- Correction**
- Reevaluate the interference fit.
  - Review operating conditions.
  - Improve the precision of the shaft and housing.
  - Fix of the faces of inner/outer ring

**Speckles and discoloration** Luster of raceway surfaces is gone; surface is matted, rough, and / or evenly dimpled. Surface covered with minute dents.

- Inner ring of double-row tapered roller bearing
- Speckles and discoloration on the raceway surface.
- Electrolytic corrosion is the cause.
- Ball of deep groove ball bearing
- Large speckles and discoloration
- Impact with hard foreign objects and insufficient lubrication are the cause.

- Causes**
- Infiltration of bearing by foreign matter
  - Insufficient lubrication
- Correction**
- Review lubricant type and lubrication methods.
  - Review sealing mechanisms.
  - Examine lubrication oil purity (filter may be excessively dirty, etc.).

**Peeling** Patches of minute spalling or peeling (size, approx. 10 μm). Innumerable hair-line cracks visible though not yet peeling. (This type of damage is frequently seen on roller bearings.)

- Spherical rollers
- Linear peeling on the rolling element surface.
- Insufficient lubrication is the cause.
- Outer ring of deep groove ball bearing
- Peeling on the load zone of the raceway surface.

- Causes**
- Infiltration of bearing by foreign matter
  - Insufficient lubrication
- Correction**
- Review lubricant type and lubrication methods.
  - Improve sealing performance (to prevent infiltration of foreign matter).
  - Perform run-in.

Bearing damage	Damaged parts	Causes														
		Handling		Bearing periphery		Lubrication		Load		Speed		Bearing selection				
		Poor storage condition/vibration during transportation	Improper handling/installation	Infiltration of bearing by foreign matter (insufficient sealing performance)	Insufficient accuracy of shaft/housing	Temperature (heat effect)	Lubricant (insufficient/improper quality)	Lubrication method (insufficient)	Excessively large moment load/preload	Excessively large impact	Excessively small load	High speed/rapid acceleration and deceleration	Large vibration	Swinging/vibration/standstill	Excessively large/small clearance	Excessively large/small interference
Spalling (Flaking)	Raceway surface/rolling element surface	○	○	○	○	○	○	○	○	○					○	
Seizure	Raceway/rolling element/cage	○				○	○	○	○	○	○				○	
Cracks/chips	Raceway/rolling element	○	○													○
Cage damage	Rivets break or become loose	○			○										○	
Rolling path skewing	Raceway surface	○	○													○
Smearing/scuffing	Raceway surface/rolling element surface/rib surface/roller end surface		○	○							○					
Rust/corrosion	Rust on a part of or the entire surface of the rolling element pitch	○	○			○		○	○							
Fretting	Red rust on fitting surface		○								○				○	
	Brinelling indentations form on the raceway of the rolling element pitch	○						○	○						○	○
Wear	Raceway surface/rolling element surface/rib surface/roller end surface		○			○		○	○							
Electrolytic corrosion	Pits form on the raceway. The pits gradually grow into ripples.		○													
Scratching and Denting	Raceway surface/rolling element surface		○			○					○	○				
Creeping	Fitting surface		○	○			○				○					○
Speckles and discoloration	Raceway surface/rolling element surface					○		○	○							
Peeling	Raceway surface/rolling element surface					○		○	○							

Figs. [NTN 2024]

# Selected issues in bearing arrangement design

## 1. Selection of bearing fits

Proper fits between the shaft and bearing bore, as well as the housing and the outer ring, are essential. Two extreme cases may occur:

### 1. Fit too loose:

- bearing life is reduced due to creeping (micro sliding) and fretting corrosion. The shaft or housing seats will wear and become damaged. Wear particles may enter the interior of bearing causing additional wear, vibration and temperature increase,
- lost of accuracy.

### 2. Fit too tight:

- damage of the bearing,
- difficulties during mounting and dismantling,
- additional stresses in the bearings and shaft, when the fit should allow axial movement to compensate for shaft thermal expansion or dimensional tolerance accumulation.

To prevent bearing damage due to excessive interference, an approximate rule states that the maximum interference should not exceed 1/1 000 of the shaft diameter.

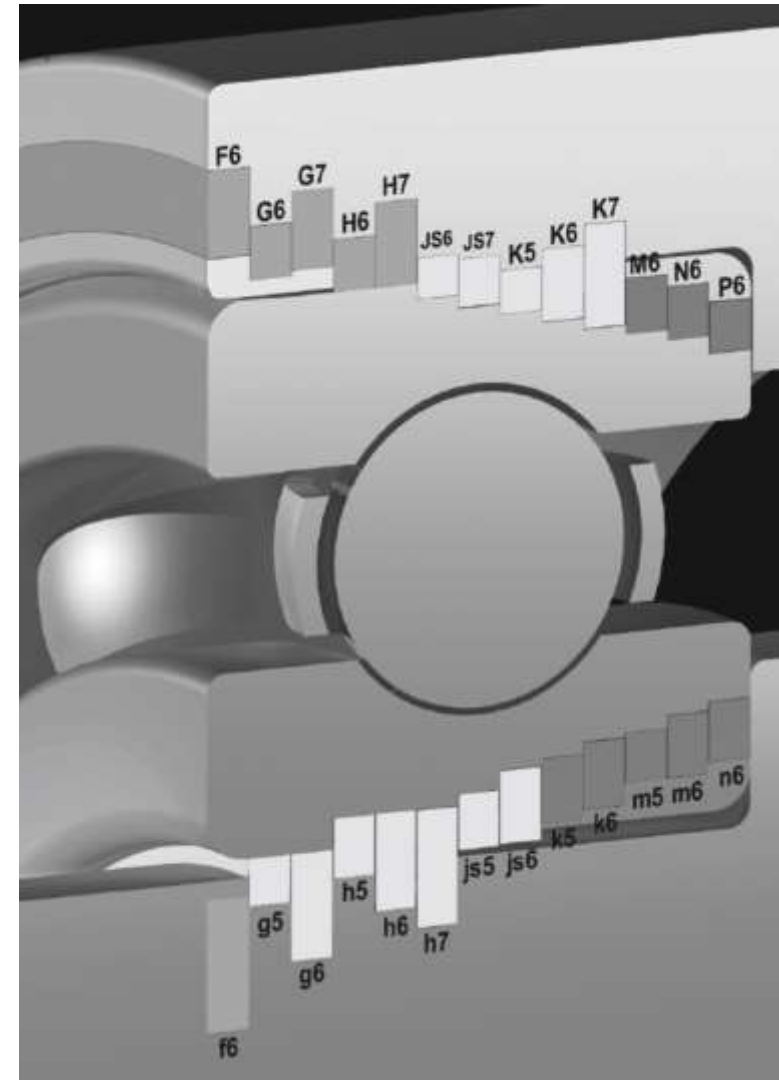

Fig. [NSK 2011]

# Selected issues in bearing arrangement design

## 1. Selection of bearing fits

Bearings are manufactured with tolerances in accordance with standards. According to ISO standards the minimum accuracy class is the Normal Class (Class 0) used for standard bearings. Other classes define precision bearings.

In the metric system the upper deviation for the inner ring bore  $ES$  and the outer ring outside diameter  $es$  is equal to zero. The lower deviations  $EI$  and  $ei$  have negative value.

Accuracy of rolling bearings is defined by dimensional tolerance and running accuracy.

Table 7.1 Bearing Types and Tolerance Classes

Bearing Type		ISO 492	ISO 492	ISO 492	ISO 492	ISO 492	ISO 492	ISO 492	ISO 492	
Deep Groove Ball Bearings		Normal	-	Class 6	Class 5	Class 4	Class 2			
Angular Contact Ball Bearings		Normal	-	Class 6	Class 5	Class 4	Class 2			
Self-Aligning Ball Bearings		Normal	-	Class 6 Equivalent	Class 5 Equivalent	-	-			
Cylindrical Roller Bearings		Normal	-	Class 6	Class 5	Class 4	Class 2			
Needle Roller Bearings		Normal	-	Class 6	Class 5	Class 4	-			
Spherical Roller Bearings		Normal	-	Class 6	Class 5	-	-			
Tapered Roller Bearings	Metric Design	ISO 492	Normal	Class 6X	Class 6	Class 5	Class 4	-		
	Inch Design	ANSI/AFBMA Std.19.2	Class 4	-	Class 2	Class 3	Class 0	Class 00		
	J Series	ANSI/AFBMA Std.19.1	Class K	Class N	-	Class C	Class B	-		
Magnet Bearings		BAS1061	Normal	-	Class 6	Class 5	-	-		
Thrust Ball Bearings			Normal	-	Class 6	Class 5	Class 4	-		
Thrust Roller Bearings		ISO 199	Normal	-	-	-	-	-		
Thrust Spherical Roller Bearings			Normal	-	-	-	-	-		
Equivalent standards (Reference)	JIS <sup>(1)</sup>	JIS B 1514,1536	Class 0	-	Class 6	Class 5	Class 4	Class 2		
	Tapered Roller Bearings	Metric Design	JIS B 1514	Class 0	Class 6X	(Class 6)	Class 5	Class 4	-	
	DIN <sup>(2)</sup>	DIN620	P0	-	P6	P5	P4	P2		
	ANSI/AFBMA <sup>(3)</sup>	Ball Bearings	ANSI/AFBMA Std.20	ABEC1	-	ABEC3	ABEC5	ABEC7	ABEC9	
		Roller Bearings		RBEC1	-	RBEC3	RBEC5	-	-	
		Instrument Ball Bearings	ANSI/AFBMA Std.12.2	-	-	-	Class 5P	Class 7P	Class 9P	
BAS	Tapered Roller Bearings	Metric Design	Multi/Four-Row	BAS1002	Class 0	-	-	-	-	

Notes

- (1) JIS : Japanese Industrial Standards
- (2) DIN : Deutsches Institut fuer Normung
- (3) ANSI/AFBMA : The American Bearing Manufacturers Association

Fig. [NSK 2011]

Nominal bore diameter $d$	Deviation of mean bore diameter in a single plane $\Delta d_{imp}$	Deviation of mean bore diameter in a single plane									
		Class 0		Class 6		Class 5		Class 4 <sup>(1)</sup>		Class 2 <sup>(1)</sup>	
mm		Upper	Lower	Upper	Lower	Upper	Lower	Upper	Lower	Upper	Lower
0.6 <sup>(4)</sup>	2.5	0	-8	0	-7	0	-5	0	-4	0	-2.5
2.5	10	0	-8	0	-7	0	-5	0	-4	0	-2.5
10	18	0	-8	0	-7	0	-5	0	-4	0	-2.5
18	30	0	-10	0	-8	0	-6	0	-5	0	-2.5
30	50	0	-12	0	-10	0	-8	0	-6	0	-2.5
50	80	0	-15	0	-12	0	-9	0	-7	0	-4

Fig. [NTN 2024]

# Selected issues in bearing arrangement design

## 1. Selection of bearing fits

One bearing required to settle two fits: between the shaft and the inner ring as well as between the housing and the outer ring. Based on previous information it may be concluded that loose fit should generally be avoided due to its disadvantages and that a properly selected tight fit should be used. However, in practical applications a loose fit is applied under certain conditions. It is necessary to facilitate assembly and disassembly in the case of non-separable bearings and when axial displacement of bearing relative to seat is required.

Guidance on the appropriate type of fit is presented in the table. In general, if the load may cause a ring to rotate relative to its seat, a tight fit is required. When high peak loads occur, significant vibrations are present, unbalance exist at high rotational speed or direction of load cannot be determined this type of load is referred to as an indeterminate load. In this case a tight fit should be applied to both bearing rings.

Load Application	Bearing Operation		Load Conditions	Fitting	
	Inner Ring	Outer Ring		Inner Ring	Outer Ring
	Rotating	Stationary	Rotating Inner Ring Load	Tight Fit	Loose Fit
	Stationary	Rotating	Stationary Outer Ring Load		
	Stationary	Rotating	Rotating Outer Ring Load	Loose Fit	Tight Fit
	Rotating	Stationary	Stationary Inner Ring Load		
Direction of load indeterminate due to variation of direction or unbalanced load	Rotating or Stationary	Rotating or Stationary	Direction of Load Indeterminate	Tight Fit	Tight Fit

Fig. [NSK 2011]

# Selected issues in bearing arrangement design

## 1. Selection of bearing fits

Three types of fits are presented in the figure. This applies to rolling bearings of medium size with Normal tolerance according to ISO standards. The tolerance classes for the shaft (e.g. f6) are shown at the bottom and those for the housing bore (e.g. F7) at the top. In combination with bearing tolerances, they enable the selection of loose, transition or interference fits.

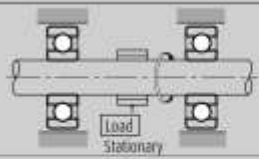
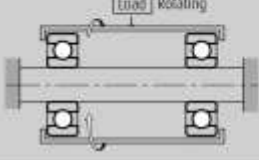
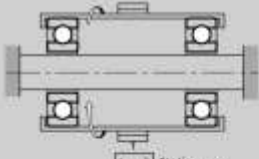
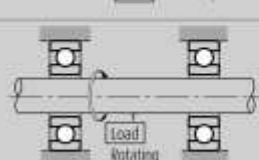
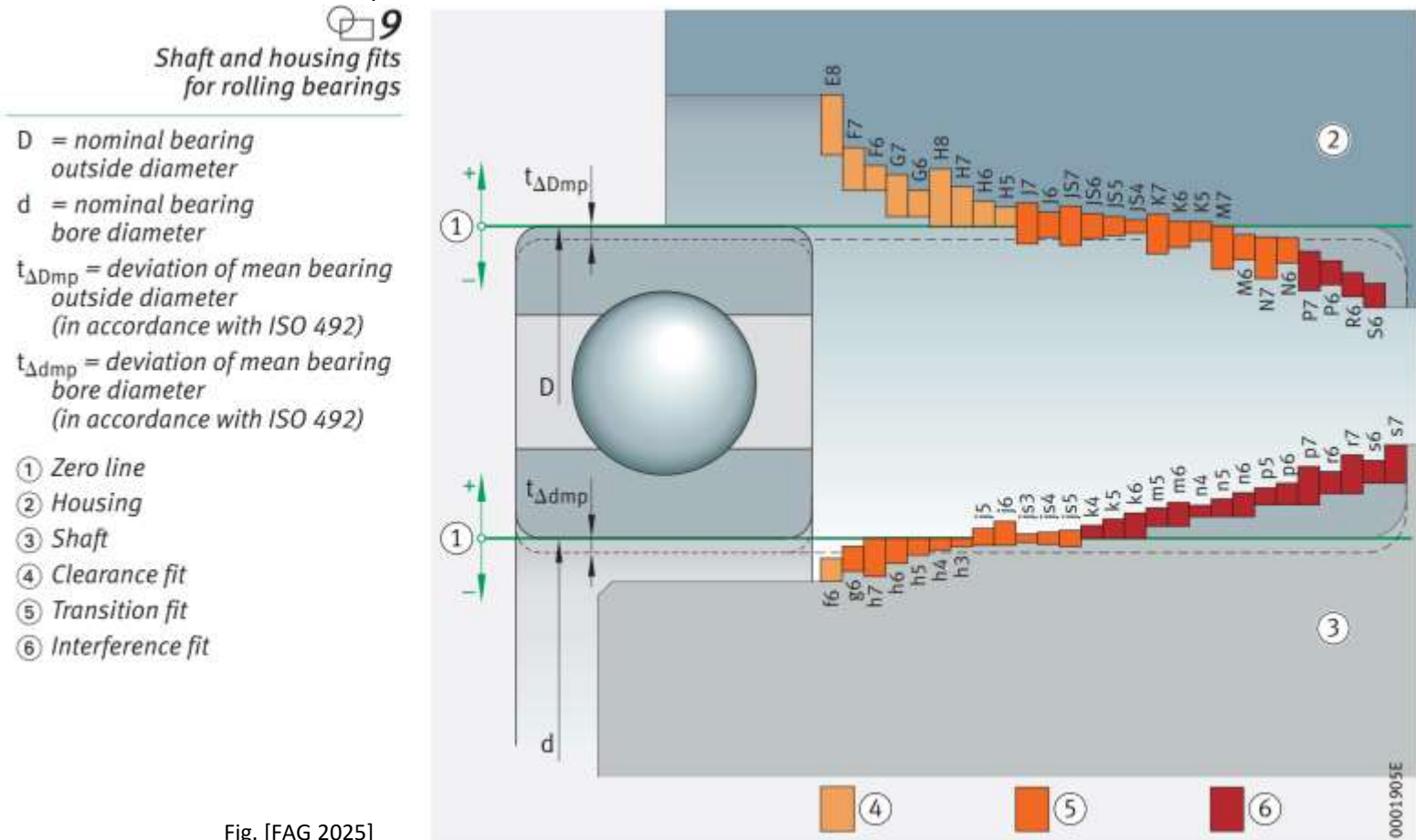

Fig. [FAG 2025]

# Selected issues in bearing arrangement design

## 1. Selection of bearing fits

A more precise assessment of the required minimum interference of the bearing inner ring may be performed using formulas that take into account the reduction of interference caused by radial load:

for  $\frac{F_r}{C_0} \leq 0,25$

$$\Delta_P = 0,08 \sqrt{\frac{d F_r}{B}}$$

for  $\frac{F_r}{C_0} > 0,25$

$$\Delta_P = 0,02 \frac{F_r}{B}$$

where:

$\Delta_P$  – required effective interference in  $\mu\text{m}$ ,

$d$  – bearing bore diameter in mm,

$F_r$  – radial force (load) in N,

$C_0$  – static load rating in N,

$B$  – bearing width in mm.

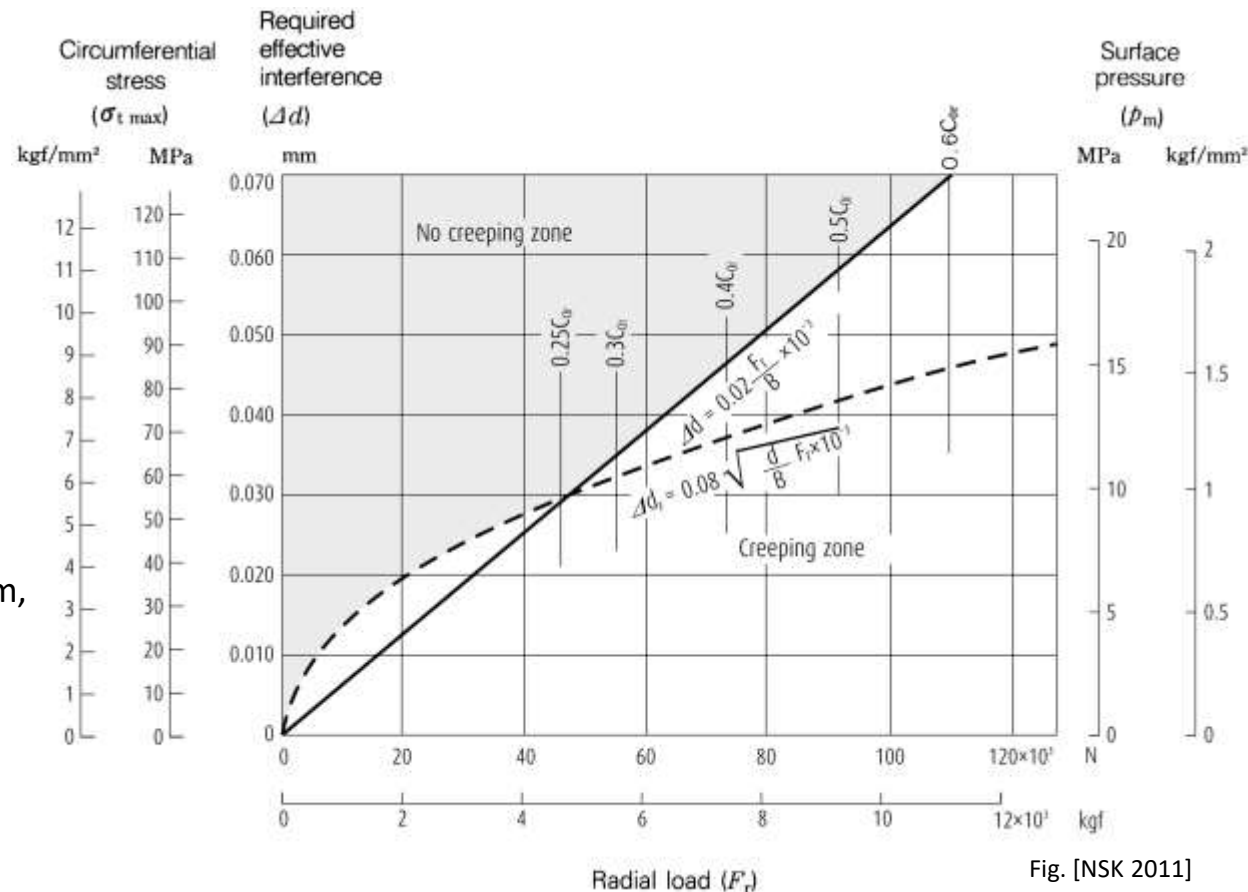

Fig. [NSK 2011]

# Selected issues in bearing arrangement design

## 1. Selection of bearing fits

Recommended shaft tolerance class

Table 7.2 General standards for radial bearing fits (JIS Class 0, 6X, 6)

Table 7.2 (1) Tolerance class of shafts commonly used for radial bearings (Classes 0, 6X and 6)

Condition		Ball bearing		Cylindrical roller bearing Tapered roller bearing		Spherical roller bearing		Shaft tolerance class	Remarks
		Shaft diameter (mm)							
		Over	Incl.	Over	Incl.	Over	Incl.		
Cylindrical bore bearing (Classes 0, 6X and 6)									
Inner ring rotational load or load of undetermined direction	Light load <sup>1)</sup> or Fluctuating load	—	18	—	—	—	—	h5 js6 k6 m6	When greater accuracy is required js5, k5, and m5 may be substituted for js6, k6, and m6.
		18	100	—	40	—	—		
		100	200	40	140	—	—		
	Normal load <sup>1)</sup>	—	18	—	—	—	—	js5 k5 m5 m6 n6 p6 r6	Alteration of inner clearances to accommodate fit is not a consideration with single-row angular contact bearings and tapered roller bearings. Therefore, k5 and m5 may be substituted for k6 and m6.
		18	100	—	40	—	40		
		100	140	40	100	40	65		
		140	200	100	140	65	100		
		200	280	140	200	100	140		
	Heavy load <sup>1)</sup> or Impact load	—	—	50	140	50	100	n6 p6 r6	Use bearings with larger internal clearances than CN clearance bearings.
—		—	140	200	100	140			
—		—	200	—	140	200			
Static inner ring load	Inner ring must move easily over shaft	Overall shaft diameter						g6	When greater accuracy is required use g5. For large bearings, f6 will suffice to facilitate movement.
	Inner ring does not have to move easily over shaft	Overall shaft diameter						h6	When greater accuracy is required use h5.
Center axial load		Overall shaft diameter						js6	Generally, shaft and inner rings are not fixed using resultant fits.
Tapered bore bearing (Class 0) (with adapter or withdrawal sleeve)									
Full load		Overall shaft diameter						h9/IT5 <sup>2)</sup>	h10/IT7 <sup>2)</sup> will suffice for power transmitting shafts.

1) Standards for light loads, normal loads, and heavy loads

Fig. [NTN 2024]

- Light loads: dynamic equivalent radial load  $\leq 0.05C_r$
- Normal loads:  $0.05C_r <$  dynamic equivalent radial load  $\leq 0.10C_r$
- Heavy loads:  $0.10C_r <$  dynamic equivalent radial load

2) IT5 and IT7 show shaft roundness tolerances, cylindricity tolerances, and related values.

Note: 1. All values and fits listed in the above tables are for solid steel shafts.

2. For ULTAGE™ series spherical roller bearings, refer to Table 2 (B-213) in bearing ta

Table 7.2 (2) Fit with shaft [fits for tapered bore bearings (Class 0) with adapter assembly/ withdrawal sleeve]

Full load	All bearing types	Tolerance class	h9 /IT5 <sup>2)</sup>	General applications
			h10/IT7 <sup>2)</sup>	Transmission shafts, etc.

# Selected issues in bearing arrangement design

## 1. Selection of bearing fits

Recommended housing hole tolerance class

Table 7.2 (3) Tolerance class of housing bores commonly used for radial bearings (Classes 0, 6X and 6)

Housing	Conditions		Housing bore tolerance class	Remarks		
	Load type, etc.	Outer ring axial direction movement <sup>3)</sup>				
Single housing or Split housing	Static outer ring load	All types of loads	Yes	H7	G7 can be used for large bearings or bearings with large temperature differential between the outer ring and housing.	
		Light <sup>1)</sup> or ordinary load <sup>1)</sup>	Yes	H8	—	
		Shaft and inner ring become hot	Easily	G7	F7 can be used for large bearings or bearings with large temperature differential between the outer ring and housing.	
Single housing	Indeterminate load	Requires precise rotation under light or ordinary loads	As a rule, it cannot move.	K6	Primarily applies to roller bearings.	
			Yes	JS6	Primarily applies to ball bearings.	
		Requires low noise operation	Yes	H6	—	
	Indeterminate load	Light or ordinary load	Yes	JS7	If high accuracy is required, JS6 and K6 are used in place of JS7 and K7.	
		Ordinary or heavy load <sup>1)</sup>	As a rule, it cannot move.	K7		
		High impact load	No	M7		
	Rotating outer ring load	Rotating outer ring load	Light or fluctuating load	No	M7	—
			Ordinary or heavy load	No	N7	Primarily applies to ball bearings.
			Heavy load or large impact load with thin wall housing <sup>2)</sup>	No	P7	Primarily applies to roller bearings.

1) Standards for light loads, normal loads, and heavy loads

- Light loads: dynamic equivalent radial load  $\leq 0.05C_r$
- Normal loads:  $0.05C_r < \text{dynamic equivalent radial load} \leq 0.10C_r$
- Heavy loads:  $0.10C_r < \text{dynamic equivalent radial load}$

2) The axial direction needs to be secured because the outer ring may move in the shaft direction, causing problems, depending on the use. (Example: planetary gear, etc.)

3) Indicates whether or not outer ring axial movement is possible with non-separable type bearings.

Note: 1. All values and fits listed in the above tables are for cast iron or steel housings.

2. If only a center axial load is applied to the bearing, select a tolerance class that provides clearance for the outer ring in the radial direction.

# Selected issues in bearing arrangement design

## 1. Selection of bearing fits – general remarks

The presented information applies for favourable conditions and does not consider all aspects that influence the required fit. The following aspects should be considered:

- *material* – the recommended fits apply to steel and iron cast shaft and housing. If a softer material, such as light alloys is used, a tighter fit should be selected.
- *hollow shaft* – a tighter fit should be used because contact pressure is reduced compared to a solid shaft,
- *split housing* – in this case, a loose fit is most often used. A tight fit may deform the outer ring into an oval shape. For tighter fits, higher geometrical accuracy and greater seat stiffness are required,
- *temperature* – due to friction bearing rings usually operate at a higher temperature than the shaft and housing seats. This reduces the tightness of the inner ring fit and increases the tightness of the outer ring fit. It also affects internal bearing clearance,
- *surface roughness* – during assembly, the theoretical interference is reduced due to flattening of surface irregularities. The lower the surface roughness  $R_a$  of the seats, the smaller the reduction in interference.
- *continuity of seats* – slots, grooves, or other discontinuities in the seats may reduce the tightness of the fit and cause non-uniform support of the bearing rings. Bearing seats should have continuous and sufficient wall thickness ensuring uniform support.

More detailed information can be found in specialised literature and manufacturers' catalogues.

Surface roughness of bearing seats				
Seat diameter		Ra (guideline values for ground seats)		
d, D		Diameter tolerance grade		
>	≤	IT7	IT6	IT5
mm		µm		
–	80	1,6	0,8	0,4
80	500	1,6	1,6	0,8
500	1 250	3,2 <sup>1)</sup>	1,6	1,6

<sup>1)</sup> When using the oil injection method for mounting, Ra should not exceed 1,6 µm.

Figs. [SKF 2018]

Relationship of interference  $\Delta_H$ , needed for a hollow steel shaft, to the known interference  $\Delta_S$  for a solid steel shaft

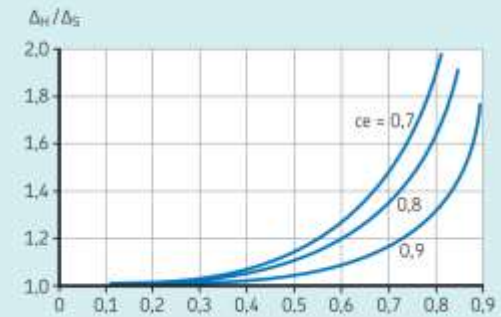

# Selected issues in bearing arrangement design

## 2. Sealing of bearing

Contamination of a bearing has a destructive effect on its performance. It may lead to premature wear, lower accuracy, increased noise and vibration. The progression of bearing degradation depends on the severity and type of contamination. Therefore, appropriate seal design should be implemented to prevent deterioration caused by contamination. The type, quantity, and configuration of the seal are influenced by the following conditions:

- type of bearing lubricant (oil or grease),
- severity and nature of contamination (fluid, particulate matter or both),
- operational temperature,
- rotational speed,
- shaft orientation (horizontal or vertical),
- available installation space,
- cost,
- maintenance requirements.

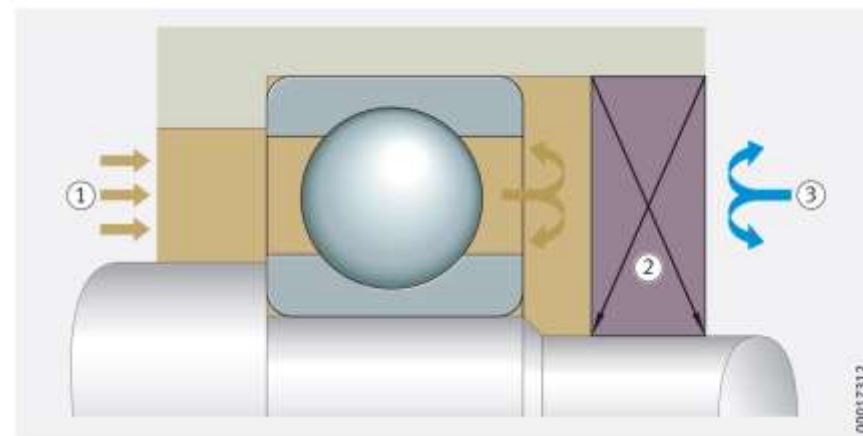
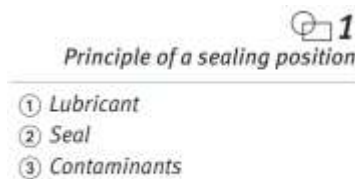

Figs. [FAG 2025]

# Selected issues in bearing arrangement design

## 2. Sealing of bearing

Seals are most often classified according to the presence of contact between their elements: **contact seals**, in which two mating surfaces are in contact, and **non-contact seals**, in which there is no contact between the mating surfaces.

Non-contact seals have following advantages:

- absence of friction, resulting in: no wear of the seal and the mating component, no power losses, no temperature increase that could affect for example the bearing clearance,
- no rotational speed limitation,
- no inherent temperature limitation then manufactured from metal.

The principal disadvantage of non-contact seals is their lower sealing effectiveness compared with contact seals.

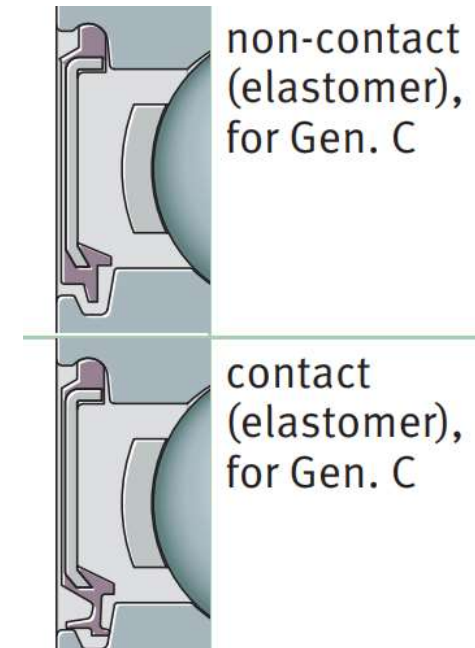

Fig. [FAG 2025]

# Selected issues in bearing arrangement design

## 2. Sealing of bearing – internal sealing

A bearing may be sealed either by internal seals or external sealing arrangements. Internal sealing may take the form of shields (designated ZZ in the figure) or seals (designated 2RS in the figure). Internal sealing may be provided on one or both sides of the bearing. It is made during the manufacturing process and in the case of sealing on both sides, the bearing is filled with grease that is usually sufficient for its service life. Internal sealing offer the following advantages:

- it is cost effective,
- it requires little or no additional installation space,
- depended on the type of seal it may be selected to suit specific operating conditions such as the type and intensity of contamination, operating temperature or rotational speed.

The limitations of internal sealing include the fact that not all type of bearings are produced with internal sealing. Furthermore, in cases of severe contamination, multi-stage sealing may be required. Internal sealing is also commonly used in combination with external sealing arrangements.

The types and properties of internal seals have been presented in the preceding section.



Fig. Internal seals and the absence of sealing  
[<https://www.sdtflbearing.com/blog/understanding-ball-bearing-seal-types-and-their-codes/>]



Fig. External seals [https://cowseal.com/types-of-shaft-seals/]

# Selected issues in bearing arrangement design

## 2. Sealing of bearing – external non-contact sealing

Application of a **gap seal**:

- suitable for dry and dust free environment,
- used with grease lubrication (without or without concentric grooves) or with oil lubrication (with helical grooves), grooves provide an increased level of protection,
- the sealing performance is enhanced when the grooves are filled with grease,
- simple and cost-effective solution.

Non-contact sealing performs most effectively during shaft rotation.

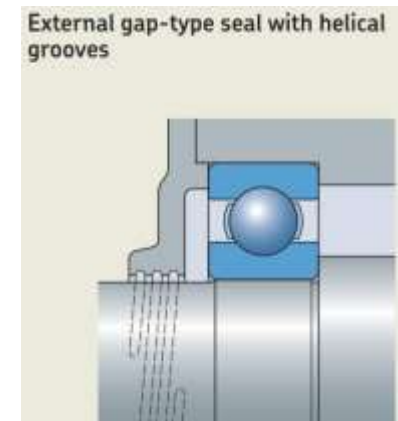
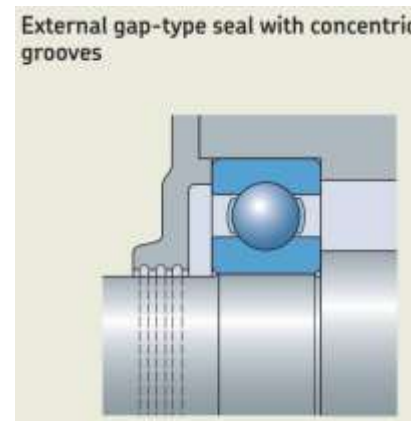
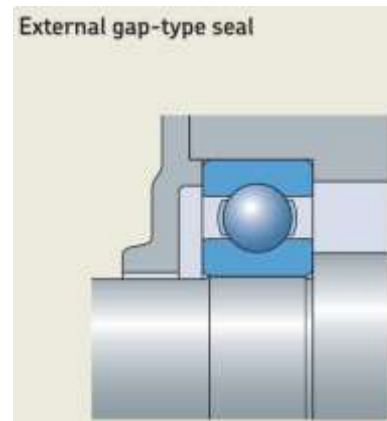

Figs. Gap seals [SKF 2018]

The approximate groove parameters are as follows:

- width: 2 – 5 mm,
- depth: 4 – 5 mm,
- gap between shaft and housing:
  - 0,25 – 0,4 mm for shaft diameters up to 50 mm,
  - 0,5 – 1,5 mm for shaft diameters between 50 and 200 mm,
- the minimum number of grooves is three when used solely.

# Selected issues in bearing arrangement design

## 2. Sealing of bearing – external non-contact sealing

Application of a **baffle plate**:

- suitable for dry and dust free environment (provides minimum protection),
- intended for grease lubrication,
- requires minimal installation space.

*Baffle plates and integrated sealing shields*

- ① Baffle plate braced on outer edge
- ② Baffle plate braced on inner edge
- ③ Sealing shields integrated on both sides

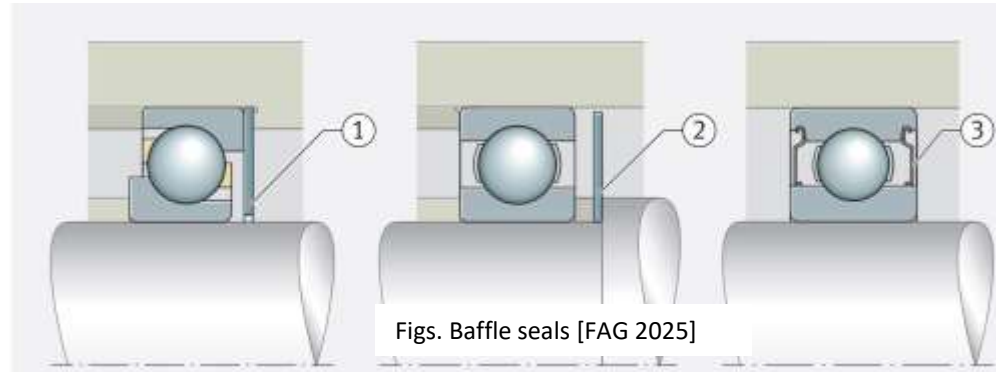

Figs. Baffle seals [FAG 2025]

Application of a **finger shield (collar)**:

- used as additional protective solution,
- depend on place of mounting can be used to prevent contamination of bearing or prevent oil to get outside,
- simple and cost-effective solution.

*Flinger shields*

- ① Sheet metal shield as flinger shield
- ② Simple rubber shield as flinger shield
- ③ Flinger shield with sheet metal reinforcement in bearing unit with sealing washer

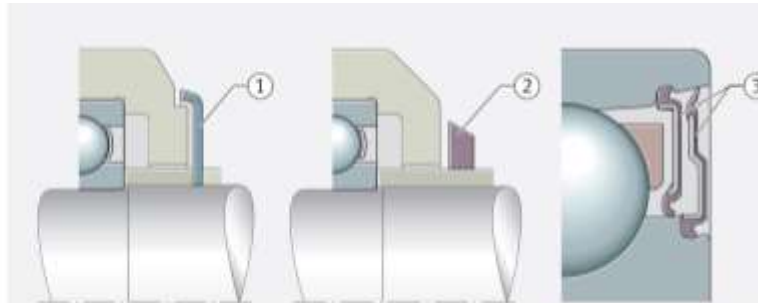

*Splash rings*

- ① Splash rings
- ② Housing with collector groove and drain hole

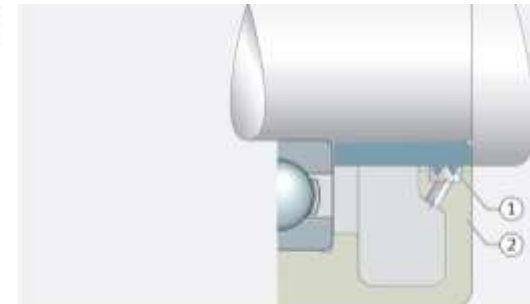

Figs. [FAG 2025]

# Selected issues in bearing arrangement design

## 2. Sealing of bearing – external non-contact sealing

Application of **labyrinth seal**:

- suitable for wet and dust environment especially when filled with grease,
- radial arrangement gives better results, but it can be used in split housing,
- inclined passage type (taper type lubrication nipple) is applied when angular misalignment is considerable,
- intended for grease lubrication.

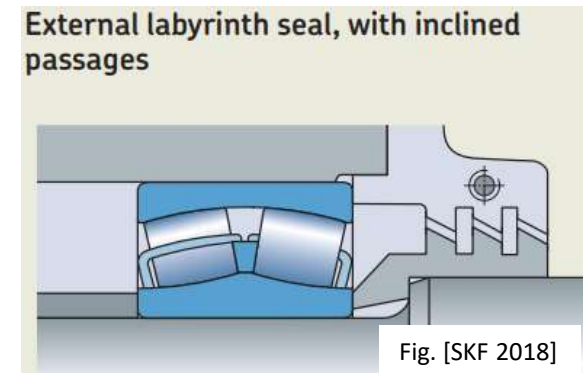
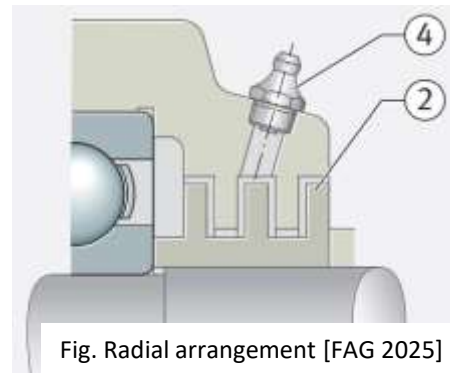
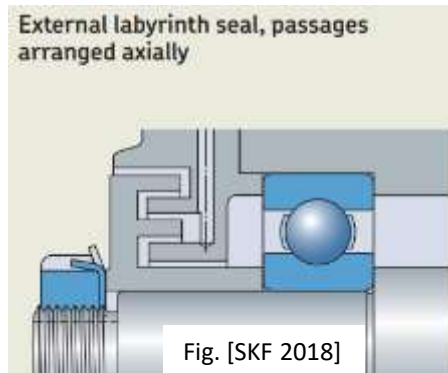

**Table 13.5 Labyrinth Seal Gaps** [NSK 2011]

Units : mm

Nominal Shaft Diameter	Labyrinth Gaps	
	Radial Gap	Axial Gap
Under 50	0.25 to 0.4	1 to 2
50-200	0.5 to 1.5	2 to 5

# Selected issues in bearing arrangement design

## 2. Sealing of bearing – external contact sealing

Application of a **radial seal (simmering, lip seal)**:

- provides highly effective sealing for oil and grease lubrication in wet and dusty operating environments,
- standard seals may be exposed to limited pressure; specialised types are available for higher pressure applications,
- subject to specific limitations and requirements regarding mating components and operating conditions.

Fig. [SKF 2020]

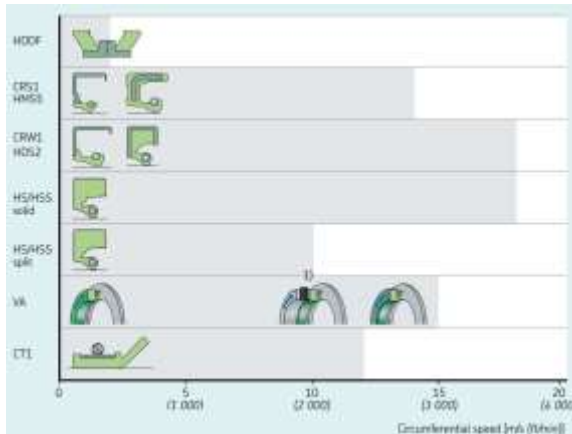

Fig. [NTN 2024]

Allowable speed/temperature according to seal type/material (reference)

Seal type/material	Allowable peripheral speed m/s $[V(m/s) = \frac{\pi \times d(mm) \times n(\min^{-1})}{60 \times 1000}]$	Allowable temp °C
Oil seal	Nitrile rubber	16 or below
	Acrylic rubber	26 or below
	Fluorinated rubber	32 or below
Z grease seal	Nitrile rubber	6 or below
V-ring	Nitrile rubber	40 or below

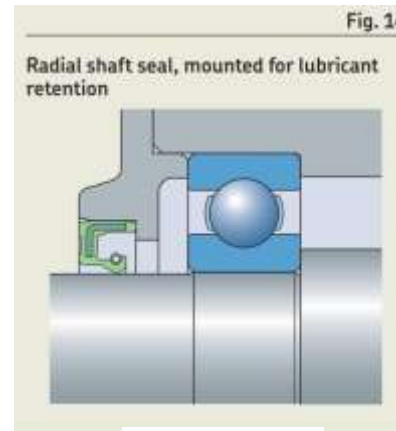

Fig. [SKF 2018]

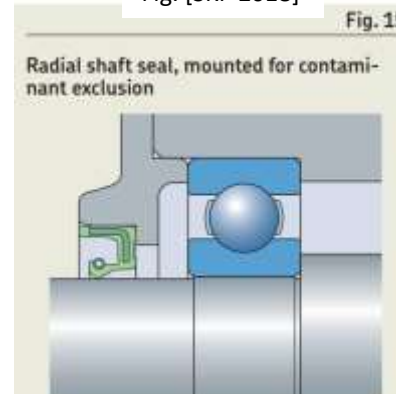

Fig. 15

Cautionary points regarding selection  
Shaft surface roughness (reference)

Peripheral speed m/s	Surface roughness	
	Ra	Rz
Up to 5	0.8	3.2
5 to 10	0.4	1.6
10 or more	0.2	0.8

Shaft material (reference)

Material	Machine structural carbon steel Low carbon alloy steel Stainless steel
Surface hardness	HRC 40 or more necessary HRC 55 or more advisable
Processing method	Final grinding without repeat (moving), or buffed after hard chrome plating

Fig. [NTN 2024]

# Selected issues in bearing arrangement design

## 2. Sealing of bearing – external contact sealing

### Radial seal (simmering, lip seal)

RG, R Nitrile rubber  
V Fluoro rubber  
T Polytetrafluoroethylene (PTFE)

Fig. [SKF 2020]

Seal designs		Design Outside diameter Configuration	Material code	Sealing lip Configuration	Material code	Auxiliary lip A = Contacting B = Non-contacting	Operating temperature range				Shaft-to-bore mis- alignment (STBM) TIR		Dynamic runout (DRO) TIR		Pressure differential		Maximum shaft surface speed	
							from	to	from	to	mm	in	mm	in	MPa	psi	m/s	ft/min
							°C		°F									
		Rubber	RG, V	Straight	RG, V	B (HM5A10)	-40	100	-40	210	0,38	0,025	0,51	0,020	0,05	7	14	2 755
		Metal	N/A	SKFWave	R, V	N/A	-40	100	-40	210	0,38	0,025	0,51	0,020	0,07	10	18	3 600
		Metal	N/A	SKFWave	R, V	B	-40	100	-40	210	0,38	0,025	0,51	0,020	0,07	10	18	3 600
		Metal	N/A	SKFWave	R, V	A (CRWA5)	-40	100	-40	210	0,13	0,005	0,13	0,005	0,35	50	10	2 000
		Metal	N/A	Straight	R, V	N/A	-40	100	-40	210	0,38	0,025	0,51	0,020	0,07	10	18	3 600
		Metal	N/A	Straight	R, V	A	-40	100	-40	210	0,38	0,025	0,51	0,020	0,07	10	18	3 600
		Metal	N/A	Straight	R, V	N/A	-40	100	-40	210	0,13	0,005	0,08	0,003	0,07	10	10	2 000
		Rubber	R	Special	R	N/A	-40	100	-40	210	0,38	0,025	0,25	0,020	0,02	3	2,54	500
			Metal	N/A	Special	T	N/A	-70	250	-95	480	*	*	*	*	*	*	*
			Metal	N/A	Special	T	A (SLA, DLA)	-70	250	-95	480	*	*	*	*	*	*	*
			Fluoroplastic/ (rubber)	T (+R, V)	Special	T	N/A	-70	250	-95	480	*	*	*	*	*	*	*

\* PTFE designs are made to order to handle temperatures, pressures and speeds that may exceed those stated for rubber sealing lip designs.

# Selected issues in bearing arrangement design

## 2. Sealing of bearing – external contact sealing

### Application of a *felt seal*:

- suitable for dust environment,
- used with grease lubrication,
- simple and cost-effective solution.

During assembly, the felt should be impregnated with oil at a temperature of approximately 80°C. The permissible rotational speed is below 4 m/s. The mating surface should have a roughness of  $R_a \leq 3,2 \mu m$ . The operating temperature should not exceed 100°C. Dimensions are standardised for example in DIN 5419.

### Application of a *metal seal*:

- suitable for dust environment,
- used with grease lubrication,
- simple with minimum requirement of installation space,
- may be applied during the repair of existing machines,
- cost-effective solution.

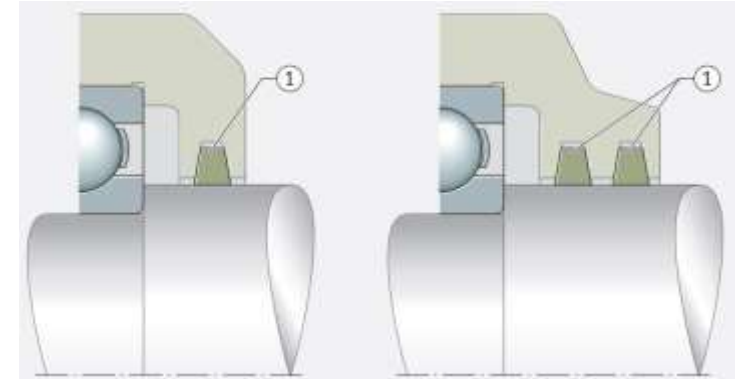

Figs. [FAG 2025]

### Metal sealing washers

- ① Sealing washers braced on inner ring
- ② Sealing washers braced on outer ring
- ③ Sealing washers in double arrangement

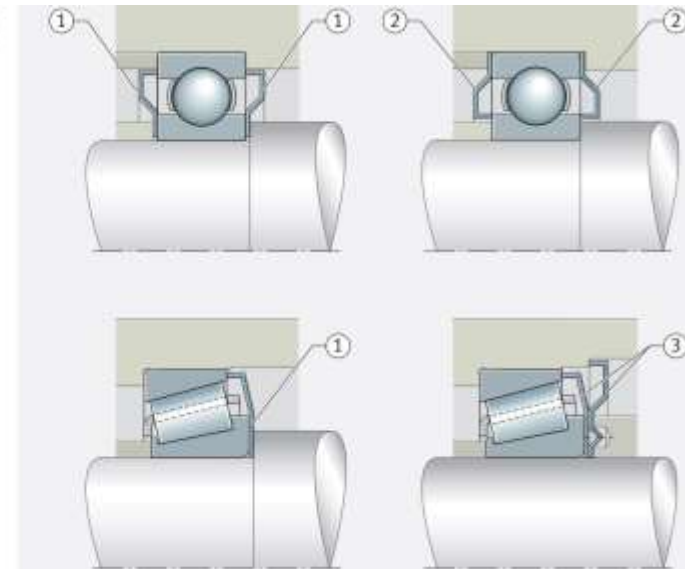

# Selected issues in bearing arrangement design

## 2. Sealing of bearing – external contact sealing

Application of a **V-ring seal**:

- suitable for wet and dust environment,
- used with grease and oil lubrication for axial shaft sealing,
- often used as a secondary seal to prevent the ingress of larger contaminants,
- suitable for application with limited space,
- capable of accommodating shaft misalignment.

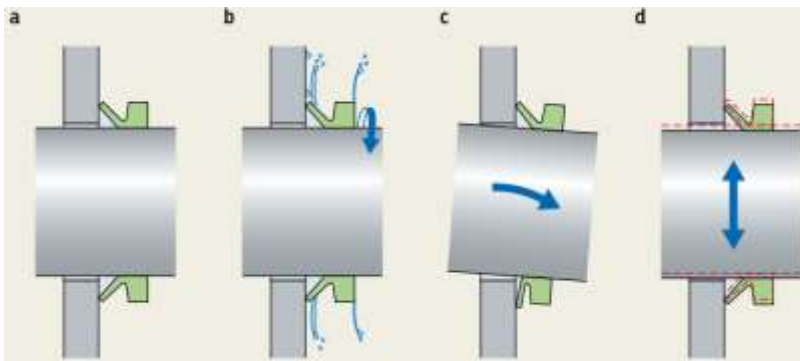

Figs. [SKF 2020]

V-ring used as a secondary seal

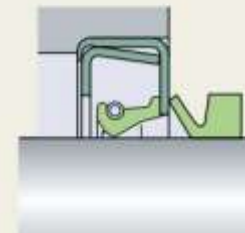

V-rings in a labyrinth seal

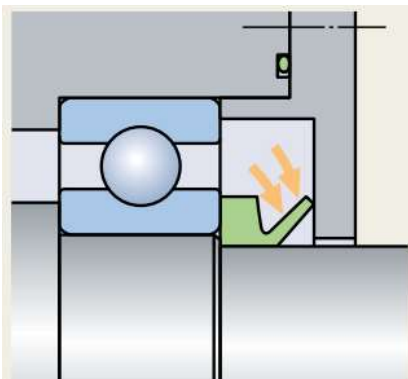
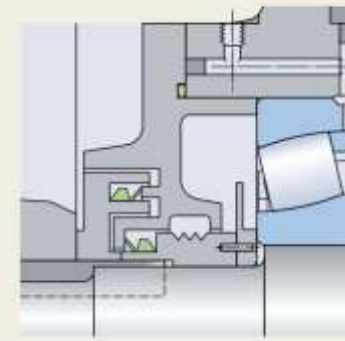
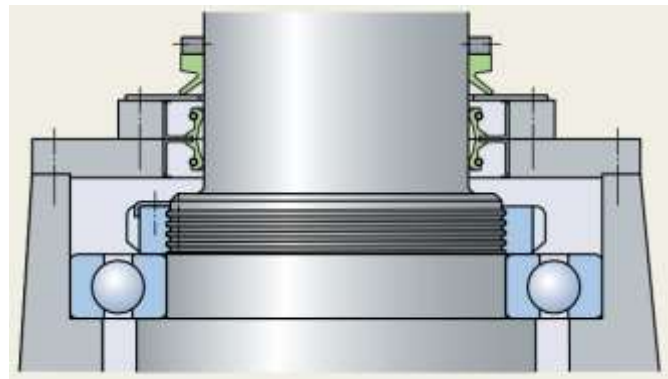
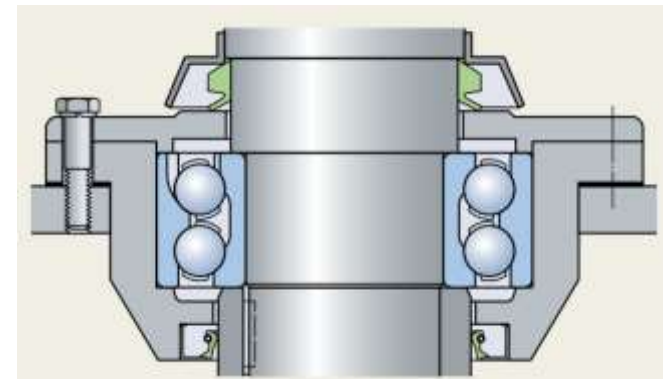

Fig. Oil retention [SKF 2020]



Figs. Contamination exclusion [SKF 2020]



# Literature

1. Budynas R. G., Nisbett J. K.: Shigley's mechanical engineering design. Mc Graw Hill 2008.
2. NSK bearing catalogue 2011.
3. SKF bearing catalogue 2018.
4. SKF industrial shaft seals 2020.
5. NTN bearing catalogue 2024.
6. FAG, Schaeffler Technologies bearing catalogue 2025.
7. Mazanek E.: Przykłady obliczeń z podstaw konstrukcji maszyn. WNT, Warszawa 2005.
8. Palmgren A.: Łożyska toczne. PWT, Warszawa 1951.
9. Harris T.A., Kotzalas M. N.: Rolling bearing analysis. Essential concepts of bearing technology. CRC Press, Taylor & Francis Group 2007.
10. Harris T.A., Kotzalas M. N.: Rolling bearing analysis. Advanced concepts of bearing technology. CRC Press, Taylor & Francis Group 2007.